

X MIND
unity

CE
0434



X-RAY EQUIPMENT FOR DENTAL INTRA-ORAL RADIOGRAPHY
INSTALLATION & MAINTENANCE MANUAL

THIS MANUAL MUST ALWAYS BE KEPT NEAR THE MEDICAL DEVICE



DETAILS OF THE DOCUMENT

File name: X-MIND_unity_Installation&maintenance_Manual_1.3c.docx

Type of document: X-MIIND unity x-ray system installation & maintenance manual.

Edition	Revision	Date	Issued by	Reviewed by	Approved by
1	3c	2013-06-05	PM	CG	MdG

Language of the original document: ENGLISH

Important: All new editions and revisions of the manuals supersede the previous ones



**Refer to complete manuals
and instructions**



**For complete manuals
and instructions**
www.satelec.com/documents



**Scan the QR code to access the
dedicated website**
www.satelec.com/documents

MANUFACTURER:

de Götzen® S.r.l. - a company of ACTEON Group

Via Roma, 45
21057 OLGiate OLONA (VA) – ITALY
Tel. +39 0331 376760
Fax +39 0331 376763

Website: www.degotzen.com - www.actedgroup.com
E-mail: degotzen@degotzen.com (for generic requests)

For technical support:

Tech. Support Webpage:
<http://support.degotzen.net>
<https://support.degotzen.net>

ITALY

For information and technical assistance, contact the manufacturer

Direct Tel.: +39 0331 376762
service@degotzen.com

WORLDWIDE

Contact your authorised local dealer.

Refer to the list in the following page to find the authorised dealer near you.

FRANCE	SATELEC ACTEON GROUP 17 avenue Gustave Eiffel - B.P. 30216 33708 Mérignac-Cedex, FRANCE Tel: +33 (0)5.56.34.06.07 Fax: +33 (0)5.56.3492.92 E-mail: satelec@acteongroup.com
GERMANY	ACTEON GERMANY GmbH Industriestrasse 9 D-40822 Mettmann, GERMANY Tel: +49 (0)2104/9565-10 Fax: +49 (0)2104/9565-11 E-mail: info@de.acteongroup.com
SPAIN	ACTEON MEDICO-DENTAL IBERICA S.A.U. Polígono Industrial Can Clapers - Avda. Principal 11H Sentmenat, 08181 Barcelona, SPAIN Tel: +34 93 715 45 20 Fax: +34 93 715 32 29 E-mail: info@es.acteongroup.com
U.K.	ACTEON UK Unit 1B - Steel Close - Eaton Socon – St. NEOTS Cams PE19 8TT, UNITED KINGDOM Tel : +44 (0)1 480477 307 Fax: +44 (0)1 480477 381 E-mail: info@uk.acteongroup.com
USA	ACTEON Inc. 124 Gaither Drive, Suite 140 Mount Laurel, NJ 08054, USA Tel:+1 8562229988 Fax:++ 1 8562224726 E-mail: info@us.acteongroup.com
SOUTH AMERICA	ACTEON LATIN AMERICA Bogotá - COLOMBIA Celular: +57 312 377 8209 e-mail : carlosandres.vera@es.acteongroup.com
RUSSIA	ACTEON RUSSIA Valdajski Proezd 16 – office 253 125445 Moscow - RUSSIA Tel./Fax. +7 499 76 71 316 e-mail : sergey.koblov@ru.acteongroup.com
THAILAND	ACTEON THAILAND LTD 23/45 Sorachai Building 16th floor - Sukumvit 63 Road, Klongton Nua - Wattana, BANGKOK 10110 - THAILAND Tel. +66 2 714 3295 Fax. +66 2 714 3296 e-mail : info@th.acteongroup.com
CHINA	ACTEON CHINA Office 401 - 12 Xinyuanxili Zhong Street - Chaoyang District - BEIJING 100027 - CHINA Tel. +86 10 646 570 11/2/3 Fax. +86 10 646 580 15 e-mail : beijing@cn.acteongroup.com
TAIWAN	14F.-1, No.433, Jingping Rd. Jhonghe Dist., New Taipei City 23563 TAIWAN (R.O.C.) Tel: +886 926 704 505 E-mail: tina.chu@tw.acteongroup.com
KOREA	ACTEON KOREA Corp. 8F Hanil B/D - 132-4 1Ga Bongrae-dong - JOONG-GU – SEOUL - KOREA Tel. +82 2 753 41 91 Fax. +82 2 753 41 93 e-mail: info@kr.acteongroup.com
INDIA	ACTEON INDIA B-94, GIDC Electronic Estate - Sector 25 – GANDHINAGAR 382028 Gujarat - INDIA Tel. +91 79 2328 7473 Fax. +91 79 2328 7480 e-mail: info@in.acteongroup.com
MIDDLE EAST	ACTEON MIDDLE EAST Numan Center - 2nd Floor N° 205 - Gardens Street PO Box 5746 - 11953 AMMAN - JORDAN Tel. +962 6 553 4401 Fax. +962 6 553 7833 e-mail : info@me.acteongroup.com
AUSTRALIA NEW ZEALAND	ACTEON AUSTRALIA/NEW ZEALAND Suite 119, 30-40 Harcourt Parade, Rosebery NSW 2018 Australia Tel. +612 9669 2292 Fax. +612 9662 2204 e-mail : sandy.junior@au.acteongroup.com

THE ELECTROMEDICAL EQUIPMENT DESCRIBED IN THIS MANUAL REFERS TO THE **X-MIND unity** MEDICAL DEVICE.

“de Götzen® S.r.l. - ACTEON Group” RESERVES THE RIGHT TO MODIFY THE PRODUCT AND ALL THE MANUALS WITHOUT PRIOR NOTICE.

IT IS PROHIBITED TO MODIFY, COPY, REPRODUCE, DISPLAY, SHARE, DISCLOSE AND PUBLISH THIS MANUAL AND ALL OTHER DOCUMENTS REFERRING TO **X-MIND unity** IN ANY FORM WITHOUT PRIOR WRITTEN CONSENT BY de GÖTZEN® S.R.L. - ACTEON Group

THIS MANUAL MUST ALWAYS BE KEPT NEAR THE MEDICAL DEVICE FOR FUTURE REFERENCE.

“de Götzen® S.r.l. - ACTEON Group” SHALL NOT BE HELD LIABLE FOR MISUSE OF THE INFORMATION PROVIDED BY THIS MANUAL.

TABLE OF CONTENTS

TABLE OF CONTENTS	6
1. INTRODUCTION	9
1.1. PRELIMINARY INFORMATIONS	9
1.2. INFORMATION FOR THE INSTALLER	10
1.3. WARRANTY CONDITIONS	11
1.4. TRANSPORT CONDITIONS	12
1.5. SAFETY WARNINGS	12
1.6. EQUIPMENT AND TOOLS NEEDED FOR THE INSTALLATION (Not Included)	17
2. RADIOGRAPHIC SYSTEM OVERVIEW	18
2.1. SYSTEM COMPONENTS	18
2.2. IDENTIFICATION TAGS	19
3. INSTALLATION REQUIREMENTS	23
3.1. ENVIRONMENT REQUIREMENTS	23
CLINICAL ENVIRONMENT CONDITIONS (OPERATING CONDITIONS)	23
TRANSPORTATION ENVIRONMENT CONDITIONS	23
WAREHOUSING ENVIRONMENT CONDITIONS	23
3.2. REQUIREMENTS OF THE SUPPORTING WALL	24
3.3. REQUIREMENTS OF THE ELECTRICAL SYSTEM	24
3.4. REQUIREMENTS OF THE ELECTRIC LINE	24
3.5. ELECTRICAL CONNECTIONS	26
4. INSTALLATION POSSIBILITIES	27
4.1. CONFIGURATION EXAMPLES	27
4.2. OVERALL DIMENSIONS	29
4.2.1. FRONT VIEW (REST POSITION) - BOTTOM MOUNT	29
4.2.2. FRONT VIEW (REST POSITION) - TOP MOUNT	29
4.2.3. SIDE VIEW (OPEN) - TOP MOUNT	30
4.2.4. SIDE VIEW (CLOSED) - TOP MOUNT	31
4.2.5. SIDE VIEW (OPEN) - BOTTOM MOUNT	32
4.2.6. SIDE VIEW (CLOSED) - BOTTOM MOUNT	33
5. INSTALLATION	34
5.1. UNPACKING	35
5.2. ASSEMBLING THE HORIZONTAL BRACKET	41
5.3. ASSEMBLING THE SCISSOR ARM	46
5.4. ELECTRICAL CONNECTIONS	60
5.5.1. OVERVIEW OF THE INTERNAL PARTS OF THE TIMER	61
5.5.2. STEP 1 - CABLES ROUTING IN THE WALL PLATE:	62
5.5.3. STEP 2 - CONNECTING INPUT POWER BOARD and INTERFACE BOARD:	63

5.5.4.	STEP 3 - GROUND POINT CONNECTION ON THE WALL PLATE:	64
5.5.5.	STEP 4 - INSTALL AND CONNECT REMOTE EXPOSURE SWITCH AND X-MIND unity LIGHT (Optional)	65
5.5.6.	STEP 5 - CONNECTING CONTROL POWER BOARD:	65
5.5.7.	STEP 6 - CONTROL BOX CONNECTIONS CHECK	66
5.5.8.	STEP 7 - CONNECTING CONTROL DISPLAY BOARD	68
5.5.9.	STEP 8 - ASSEMBLING THE TIMER:	69
6.	INSTALL AND CONNECT X-MIND unity LIGHT (OPTIONAL)	70
7.	INSTALL AND CONNECT THE REMOTE EXPOSURE SWITCH (OPTIONAL)	73
6.	START UP	75
7.	CONFIGURATION	77
7.1.	ADVANCED SETTINGS MENU (SERVICE ONLY)	79
8.	CHECKING THE INSTALLATION	81
8.1.	CHECKING THE CONFIGURATION	81
8.2.	CHECKING THE TIMER OPERATION	81
8.3.	CHECKING THE EXPOSURE	81
8.4.	CHECKING THE OPERATION OF THE TUBEHEAD	82
8.5.	CHECKING THE ABSORBED POWER	82
8.6.	CHECKING THE ELECTRIC SYSTEM	82
9.	BASICAL CHECKING OVERALL SYSTEM FUNCTIONS	83
10.	CHECKING THE EXPOSURE FACTORS	84
10.1.	CHECKING THE X-RAY TUBE VOLTAGE (kV)	84
10.2.	CHECKING THE X-RAY TUBE CURRENT (mA)	84
11.	DIAGNOSTIC	87
11.1.	X-RAY CALIBRATION PROCEDURE	87
12.	ERROR MESSAGES	88
13.	SUGGESTED MAINTENANCE AND REPAIR	91
13.1.	CLEANING THE OUTER SURFACE	92
13.2.	DISPOSAL	92
13.3.	MAINTENANCE INSTRUCTIONS	93
13.4.	REPLACEMENT OF FUSES	94
13.5.	CHANGING THE BEAM LIMITING DEVICE (Collimator Cone)	96
13.5.1.	ROUND CONE (SHORT AND LONG)	96
13.5.2.	RECTANGULAR CONE	97
13.5.3.	MODIFY INSTALLED BEAM LIMITING DEVICE IN X-MIND unity CONTROL UNIT	100
13.6.	HOW TO DISASSEMBLE THE TUBE HEAD	101
13.7.	HOW TO re-ASSEMBLE THE TUBE HEAD	104

14.	TECHNICAL SPECIFICATIONS	105
15.	ELECTRICAL SCHEMES	106
	<i>X-MIND unity Global Wiring Scheme</i>	110

1. INTRODUCTION

1.1. PRELIMINARY INFORMATIONS

Before starting with the use of the “**X-MIND unity**” x-ray system, it is mandatory to carefully read and follow the instructions contained herein in order to obtain the best performance and assure the safety of the patient, operator, device and the environment.

Always pay close attention to the messages when operating the system.

CAUTION
WARNING
PLEASE NOTE

LEGEND

 **CAUTION**

*The word **CAUTION** identifies those occurrences which might compromise the operator's personal safety or cause injuries to people.*

 **WARNING**

*The word **WARNING** identifies those occurrences which might compromise the x-ray system's performance.*

 **PLEASE NOTE**

***PLEASE NOTE** serves to give special indications to facilitate maintenance or make important information clearer.*

1.2. INFORMATION FOR THE INSTALLER

CAUTION - WARNING

The installer is responsible for the installation, with regards to the system safety and operation.

The X-MIND unity is an X-ray equipment intended to be used for dental intra-oral x-ray imaging.

For a safe and reliable installation of the X-MIND unity radiographic system, together with the strict following of the instructions and recommendations contained in the accompanying documents and provided by the manufacturer, it is further recommended to:

- Check that the rated voltage mentioned in the rating plates matches the line voltage.
- Install the radiographic system according to the procedures described in this manual and in compliance with local rules and laws of the place of installation.
- Provide the operator with any information regarding the use of the radiographic system according to what stated in the accompanying documents according to its intended use.
- Certify the work done by a “declaration of conformity”.

This manual has been written and published under the supervision of de Götzen® S.r.l. - ACTEON Group. It contains all the latest descriptions and features of the product. Although every effort is made to produce up-to-date and multi-language documentation (since each accompanying document is translated in different languages), this publication should not be regarded as an infallible guide to current specifications.

The information in this manual is periodically updated; any amendment will be included in subsequent publications without prior notice by de Götzen® S.r.l. - ACTEON Group.

Contact your dealer to request the latest version of the manual.

In the event of errors, please inform de Götzen® S.r.l. - ACTEON Group promptly.

CAUTION - WARNING

This manual describes how to install and set the X-MIND unity x-ray system.

The installer must read and understand the manual before install and set the medical device.

This manual must be always kept as a reference document and it is mandatory to comply with the instructions supplied with it.

Before install the device, it is essential to carefully read the instructions, CAUTION and WARNING messages listed in the paragraph relevant to the safety warnings.

CAUTION - WARNING

This manual does not include all the recommendations and obligations concerning installation and use of ionising radiation sources, since they differ from country to country. Therefore, only the most common are listed

Installers must refer to the laws in force in their country to meet all legal requirements.



PLEASE NOTE

For installation in USA, a report of assembly (Form FDA 2579) must be filled out to certify that the medical equipment was assembled according to the instructions provided by the manufacturer, and meets the requirements of the applicable Federal standards contained in 21 CFR 1020.30 through 1020.33.

Reports must be filed with FDA's Center for Devices and Radiological Health (CDRH) within 15 days of completion of the assembly. The report must be filled in according to the methods provided in:

<http://www.fda.gov/ForIndustry/FDAeSubmitter/ucm107879.htm>

(remember to check the updated web address since this may change over time)

1.3. WARRANTY CONDITIONS

Inappropriate use or any arbitrary tampering with, exempt "de Götzen® S.r.l. - ACTEON Group", as manufacturer of the "X-MIND unity" x-ray system, from any service under warranty or from any other liability.

The warranty is valid only if the following precautions are taken, please refer also to the warranty conditions:

- **Any repair, modification, adjustment, or any kind of technical intervention must be performed only by de Götzen® S.r.l. or by a qualified authorized representative**
- The installation must be made by professionally qualified technicians according to the regulations in force.
- The system must be installed and used in compliance with the instructions given in this operator's manual and in its associated documentation.
- The device shall be used in compliance with the purposes and applications for which it is designed.
- The power supply must be adequate to supply the required power indicated in the data contained in the labels of the device.
- **In order to safeguard your warranty rights, read carefully, fill and sign the Warranty Document provided by the seller, immediately after the installation is completed, together with the installer.**
- The system must be checked completely at least each 12 months by professionally qualified technicians according to the regulations in force. Use the manuals provided with the device **X-MIND unity** for reference.
- de Götzen S.r.l. refuse all responsibility due to any damage coming from persons or things in consequence of non-observance of all prescriptions contained in all the manuals provided with the **X-MIND unity** device.
- In case of repair, only original spare parts of the manufacturer of the **X-MIND unity** must be used.



CAUTION

Disregarding the above mentioned rules and all the indications provided by the manufacturer in the documentation, or successively in written paper or electronic format, will cause the total losing of the warranty of the product and the manufacturer will be discharged from any obligation, including consequential damages, direct or indirect that may derive to people, things or environment. Furthermore, the facility representative, customer or employees of the facility, will be liable for any damage and/or incident and/or degeneration of the health status of a patient, operator, involved people and the surrounding environment.

This also will have the result in service charges for non-warranty technical assistance.

1.4. TRANSPORT CONDITIONS

The “X-MIND unity” x-ray system travels at the receiver’s own risk.

All claims for damages or mishaps regarding the shipment must be pointed out in the presence of the shipping agent.
In case of actual or suspected damages, the receiver shall indicate the proper reserves on the way-bill or on the consignment note.

1.5. SAFETY WARNINGS

A few safety recommendations are listed here below which must be followed when using the “X-MIND unity” x-ray system.



GENERAL REQUIREMENTS

- The Installation of the X-MIND unity system must be executed only by trained, qualified and authorized service personnel.
- de Götzen S.r.l. - ACTEON Group or its authorized technicians are not allowed to check the conformity of the installation site with the local laws and regulations in terms of Electrical safety, X-ray protection or any kind of safety regulations of the country and location where the X-MIND unity is installed.
- The X-MIND unity must be installed and operated in accordance with the safety procedures and operating instructions given in the Operator’s manual, Installation & Maintenance manual and Maintenance Manual and all the connected accompanying documents for the purposes and intended use for which it was designed.
- It is mandatory for the RESPONSIBLE ORGANIZATION to provide a routine and special maintenance schedule for biomedical equipment; this schedule must be documented for every device and transmitted to the various operating levels (*).The preventive maintenance (that must be performed at least every twelve months), which includes functional, performance and safety tests of the device, must be carried out by qualified, authorised professional technicians, it is mandatory to ensure patients' health and safety and proper X-MIND unity operation (IEC 60601-1 etc.).These operations must be carried out according to the methods and frequency indicated in this manual, in the installation and maintenance manual and maintenance manual. Failure to comply with this requirement or with the messages concerning anomalies will release the manufacturer from any liability for direct and indirect injuries to persons and/or damage to property or the environment. Furthermore, the managers of the facility, customers or collaborators shall be held liable for any damage and/or accidents and/or degeneration of patients' or operators' health or of the surrounding environment. The RESPONSIBLE ORGANIZATION must also provide for the safe and proper use of the equipment.
(*). For Italy refer to Presidential Decree 14/01/1997, Legislative Decree No. 81/2008 (as subsequently amended and modified).
- Carefully follow the instructions in this manual and the accompanying documents to install and proper maintain and use the X-MIND unity device. In the event that local laws and standards are more restrictive than the manufacturer's indications, the former supersede the latter.
- The installation and placing in service of the X-MIND unity must comply with the standards and regulations in force concerning the installation of the medical device in consideration of the place and country of installation.
- The X-MIND unity must be installed in order that the operator must be able to monitor the patient throughout the entire duration of the x-ray examination.

- It is prohibited to modify or attempt to repair the electronic boards of the X-MIND unity.
- de Götzen S.r.l. - ACTEON Group and its authorised technicians are not required to verify compliance of the installation site with local standards concerning electrical safety and X-ray protection and with any other directive concerning safety in force in the country of installation.
- The RESPONSIBLE ORGANIZATION of the X-MIND unity must ensure compliance of the installation site with the local laws in force

 CAUTION

INSTALLATION OF THE SOPIX/SOPIX² INSIDE INTRAORAL X-RAY DIGITAL SENSOR

- The X-MIND unity is already partially prepared for the integration only of the optional Sopix/Sopix² Inside intraoral x-ray digital sensors manufactured by Sopro-Acteon Group.
For the proper and safe installation of the Sopix/Sopix² Inside sensor it is mandatory to strictly follow the instructions and accompanying documents relevant to the Sopix/Sopix² Inside and all the recommendations contained in the accompanying documents relevant to the X-MIND unity.
- The X-MIND unity has been certified by Accredited Laboratories ONLY for the integrated use with the Sopix/Sopix² Inside x-ray digital intraoral sensor, according to the requirements stated by the applicable standards. It is strictly forbidden to connect, trying to connect or operate in any way devices different from the Sopix/Sopix² Inside sensor manufactured by Sopro. If you don't respect this warning the overall safety of the X-MIND unity can be irreversibly compromised with the consequence of damages or injuries to patients, to operators and to the environment. Failure to comply with this requirement or with the messages concerning the presence of eventual anomalies will release the manufacturer from any liability for direct and indirect injuries to persons and/or damage to property or the environment. Furthermore, the managers of the facility, customers or collaborators shall be held liable for any damage and/or accidents and/or degeneration of patients' or operators' health or of the surrounding environment.

 CAUTION

PROTECTION AGAINST RADIATIONS

The "General principles for safeguarding and protecting the personnel and patients" must always be applied during the use of the X-ray unit.

1. Justification of the practice
 2. Optimisation of protection principle (ALARA principle)
 3. Individual risk and dose limits
- The X-MIND unity is a medical device that generates X-rays; therefore, both the patients and the operator are exposed to risks due to ionising radiation. The physician must assess the actual need for X-ray exposure.
 - All personnel present during x-ray examination must comply with safety regulations concerning protection against radiation. For his own safety, the operator must always keep a distance of more than 2 meters (6 ft.) from the x-ray beam.
 - The X-MIND unity medical device must be installed and used in compliance with the local standards in force and with the international directives concerning radiation protection.
 - Comply with the guidelines and indications provided by an accredited specialist in radiation protection, who will recommend, if necessary, the additional shields or precautions for every specific case.
 - The device installation site must be shielded in compliance with the local standards in force to protect the operator, patient and other people against X-rays.



This symbol draws the ATTENTION to X-ray hazards

- According to the paragraph 203.8.5.4 of the IEC 60601-2-65, in case you're using the X-MIND unity device together with the integrated SOPIX/SOPIX² Inside sensor, it is mandatory to install and use the original rectangular beam limiting device provided by the manufacturer of the X-MIND unity.

 CAUTION



MECHANICAL RISK

- Pay extremely attention to the tension of the internal spring of the scissor arm in order to avoid the arm opening and causing injury.
- Check that the installation of the X-MIND unity respect the mechanical specifications of the support (walls, ceiling, etc..) where it is installed
- Avoid installing the X-MIND unity in environments where severe mechanical vibration or shocks are present.
- Adjustments or any kind of attempt of repairing or disassembling must only be performed by qualified and authorized service personnel.

 CAUTION

ELECTRICAL SAFETY

- The x-ray system contains high voltage. It's not allowed to inspect internal parts of the system.
- Never attempt to open the x-ray source.
- The covers on the X-MIND unity equipment must only be removed by qualified and authorized service personnel.
- The unit must be installed only in environments that are in compliance with all the electrical safety standards set forth for medical environments.
- The unit is NOT equipped with protections against penetration of liquids; it will therefore be necessary to make sure that no water or other liquids penetrate inside so as to avoid short circuits or corrosion.
- Always disconnect the x-ray system from the power supply and wait for 2 minutes before beginning cleaning or disinfecting operations or maintenance.
- Do not connect a multiple portable socket outlet (MPSO) or extension cord to the system.
- External equipment intended for connection to signal input, signal output or other connectors shall comply with the relevant product standard e.g. IEC 60950-1 for IT equipment and the IEC 60601-series for medical electrical equipment. In addition, all such combinations – systems – shall comply with the safety requirements stated in the collateral standard IEC 60601-1-1 or the general standard IEC 60601-1, edition 3, clause 16. Any equipment not complying with the leakage current requirements in IEC 60601-1 shall be kept outside the patient environment i.e. at least 1.5 m from the patient support.
- Any person who connects external equipment to signal input, signal output or other connectors has formed a system and is therefore responsible for the system to comply with the requirements. If in doubt, contact qualified medical technician or your local representative.
- An isolation device (Separation Device) is mandatory needed to isolate the equipment located outside the patient environment from the equipment located inside the patient environment. In particular such a Separation Device is required when a network or data connection is made. The requirements on the Separation Device is defined in IEC 60601-1-1 and in IEC 60601-1, edition 3, clause 16.
- Pay extreme care of the internal cables throughout the whole unit in order not to damage them
- Basing on the IEC 60601-1, the installation of the X-MIND unity wall version is permanent type (fixed). IT IS NOT ALLOWED TO connect the equipment to the main supply using a plug
- Do not modify or try to modify any internal wiring or connector which are already present and provided in the X-Mind unity.

 WARNING -  CAUTION



ELECTRICAL SHOCK HAZARD!

For your safety, **ALWAYS** remember to turn the X-MIND unity power switch off, as well as disconnect the main power supply during installation or before carrying out any maintenance operation.

Remember as well to keep disconnected the X-MIND unity from any active powered device.

 WARNING



ESD WARNING!

Pay attention when managing PCB boards! Permanent damage may occur on devices subjected to high energy electrostatic discharges. Therefore, proper ESD precautions are recommended to avoid performance degradation or loss of functionality.

All PCB boards are made up by electronic components sensitive to electrostatic discharge (ESD). Permanent damage may occur on devices subjected to high energy electrostatic discharges. Therefore, proper ESD precautions are recommended to avoid performance degradation or loss of functionality.

 CAUTION

PROTECTION AGAINST EXPLOSIONS

The x-ray system **MUST NOT** be installed in environments with the presence of disinfectants, flammable or potentially explosive gases or vapors that might catch fire and cause damage.

In case these disinfectants have to be used let the vapors completely disperse before turning on the x-ray system.

1.6. EQUIPMENT AND TOOLS NEEDED FOR THE INSTALLATION (Not Included)

For a standard installation of the medical device X-MIND unity, the following tools are needed:

1. Drill
2. Wall tips of various size.
3. Paper tape or similar to fix template to the wall.
4. Spirit level.
5. Flexometer.
6. Set of screwdrivers, flat and cross type.
7. Click wrench (suggested dynamometer click wrench to check torque of anchor bolts).
8. Series of metric socket wrenches with extension tube.
9. Series of metric Allen keys.
10. Scissors or cable stripper.
11. Necessary tools and components to install ring and ferrules.
12. True RMS Calibrated Multimeter.

2. RADIOGRAPHIC SYSTEM OVERVIEW

2.1. SYSTEM COMPONENTS

The X-MIND unity radiographic system (Fig.1.1) consists of:

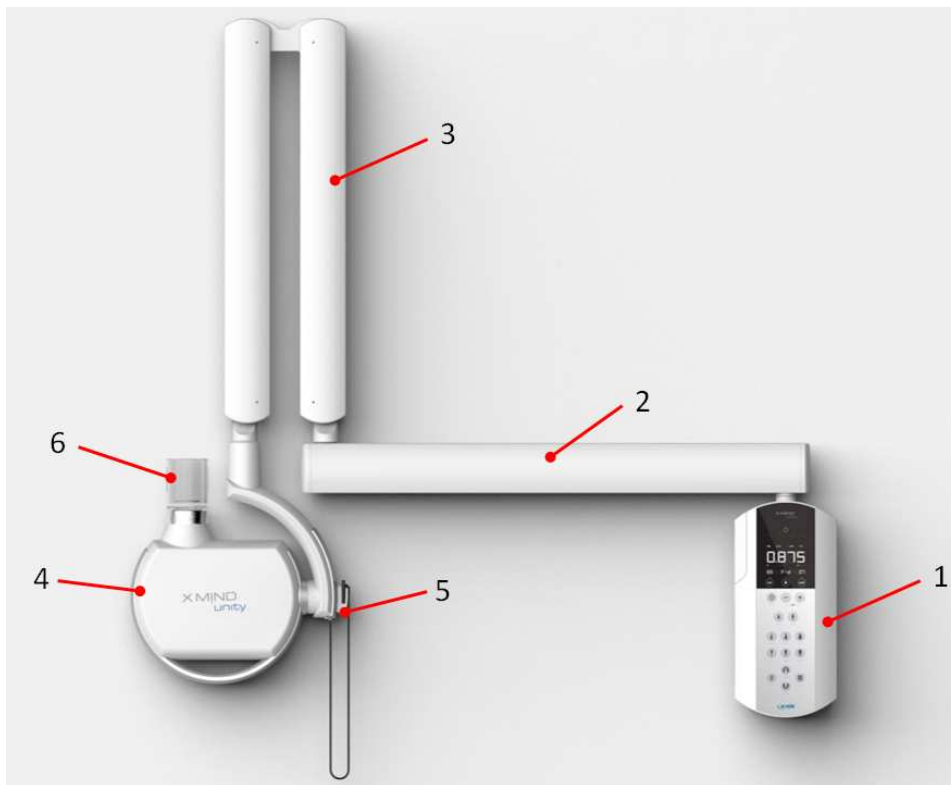

Fig.1.1

1. X-RAY CONTROL UNIT (TIMER) and WALL PLATE
2. HORIZONTAL BRACKET
3. PANTOGRAPH TYPE ARM (SCISSOR)
4. X-RAY SOURCE ASSEMBLY (TUBEHEAD)
5. Sopix/Sopix² Inside SENSOR and SENSOR HOLDER¹
6. COLLIMATOR CONE (Beam Limiting Device)
<u>OTHER OPTIONALS</u>
▶ X-MIND unity REMOTE EXPOSURE SWITCH
▶ X-MIND unity LIGHT (Rx signalling lamp for external use)

¹ Optional Sold Separately. Contact Sopro, ZAC Athélia IV • Avenue des Genévriers • 13705 LA CIOTAT cedex • FRANCE • Tél +33 (0) 442 98 01 01 • Fax +33 (0) 442 71 76 90 • E-mail: info@sopro.acteongroup.com • www.sopro.acteongroup.com

2.2. IDENTIFICATION TAGS

The identification tags on the tube head, on the timer and on the cone indicate the model number, the serial number, the manufacturing date and the symbols relevant to the main technical characteristics.

Labels for Europe:

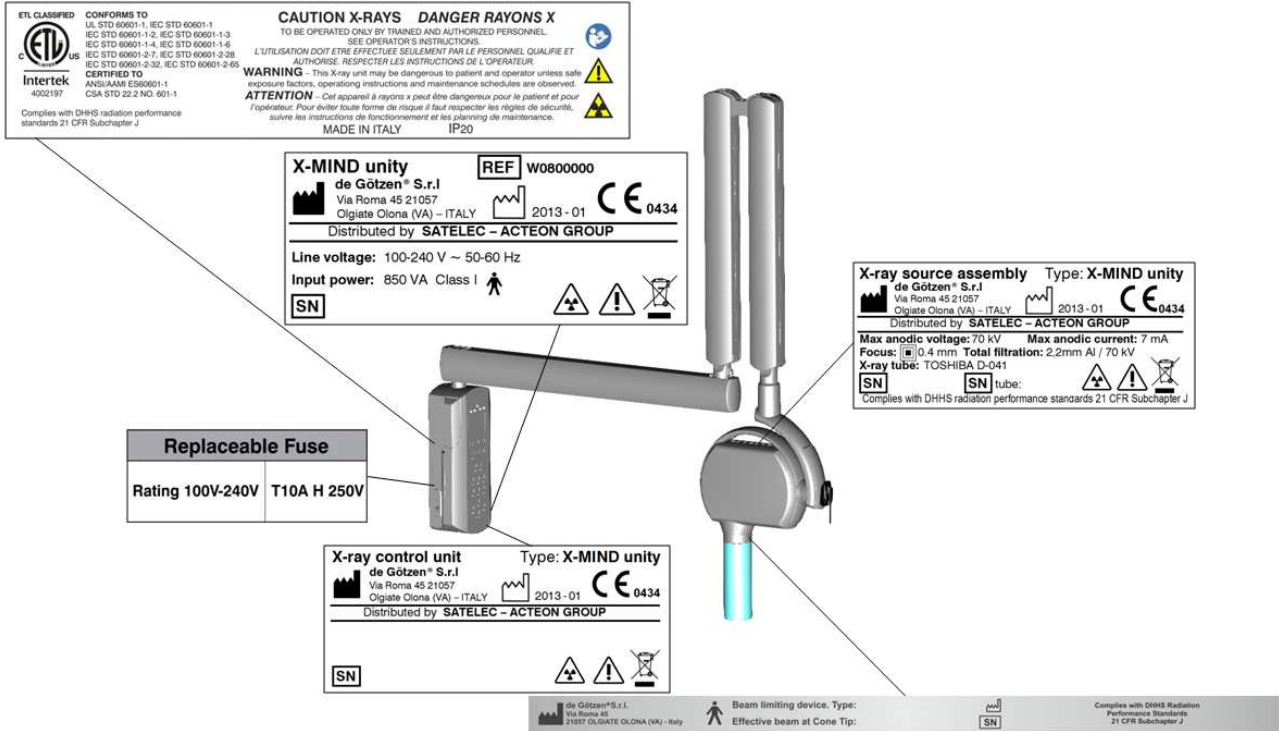

Labels for USA:

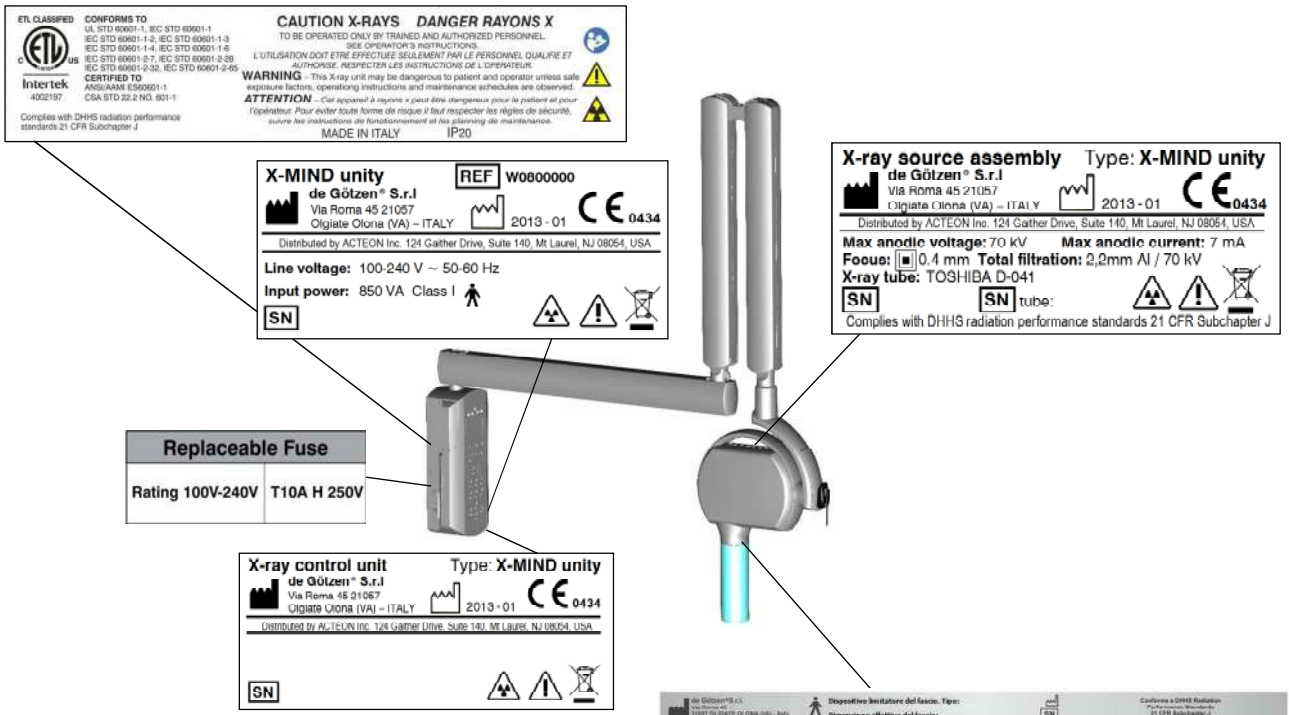

X-MIND unity global label

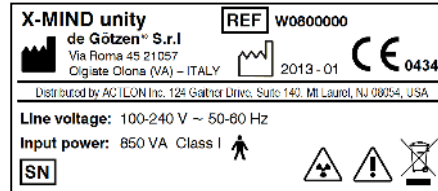
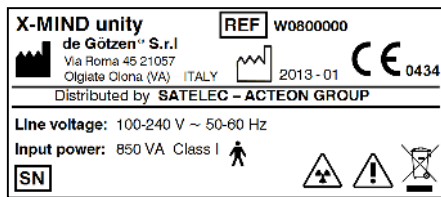

X-MIND unity Control Unit (Timer) Label

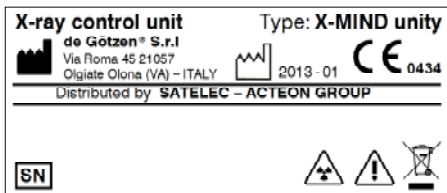

X-MIND unity X-ray source Label

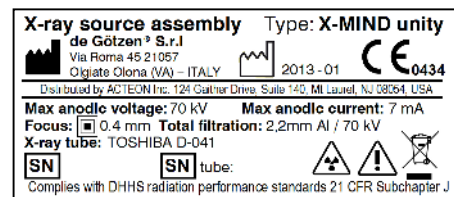
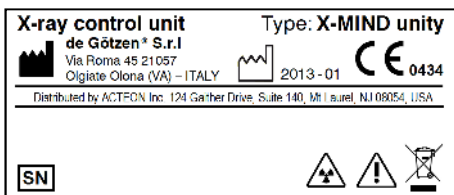
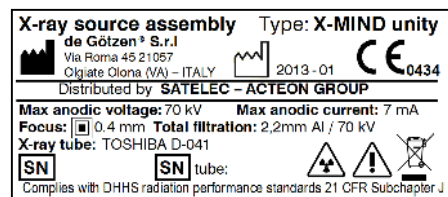

BEAM LIMITING DEVICE LABEL



















TUBEHEAD GRADUATED SCALE



ETL LABEL AND X-RAY WARNING



	En: Power ON (IEC 60417)
	En: Power OFF (IEC 60417)
	En: Protective earth (IEC 60417)
	En: Applied Part: Type B (IEC 60601-1)
	Attention, refer to the attached documents
	Ionising radiation hazard
	Emitting X-ray equipment (IEC 60417)
	Comply with the implementation standards in your country. European Council Directive 2002/96/EC (WEE) imposes the disposal or recycling of electric and electronic equipment. The product is marked with the following icon. This product must not be disposed of as domestic waste. The crossed-out wheeled bin identifies a product placed on the market after the 13th of August 2005 (see IEC EN 50419:2005). This product is subjected to Council Directive 2002/96/EC (WEEE) and implementation standards in force in your country. The product must be disposed of or recycled to protect the environment.
	Size of the focal spot (small)
	Hazardous Voltage
	Electrostatic discharge sensitive device
	Pause (IEC 60417)
	X-ray command (IEC 60417)
	THIS SYMBOL GUARANTEES THAT THE X-RAY SYSTEM COMPLIES WITH THE REGULATIONS CONTAINED IN THE EUROPEAN DIRECTIVE EEC 93/42 AND SUBSEQUENT AMENDEMENTS REGARDING MEDICAL DEVICES
	This symbol remind that is mandatory read carefully the whole documentation and manuals provided with the medical device before perform whatever operation.
 Electronic user informations	Electronic instructions for use symbol for medical devices, according to the European Commission Regulation no. 207/2012 of March 9 th , 2013.

FUSE LABEL

Replaceable Fuse	
Rating 100V-240V	T10A H 250V



NOTE

The fuse label is located close to the main switch.



CAUTION



WARNING

In case is needed to replace the line fuse, you must respect absolutely the ratings and the same specifications declared by de Götzen S.r.l. Call the technical support service for assistance.

3. INSTALLATION REQUIREMENTS



WARNING

Prior installing the radiographic system, the Office Owner and the RESPONSIBLE ORGANIZATION must ascertain that the environment, the electrical system and the power supply are complying with the requirements needed, otherwise they must ensure that the compliance is fully satisfied.

It is also necessary ascertain that the room is in accordance with the local laws and regulations regarding radiation protection and electrical safety for environments dedicated for medical purposes.

3.1. ENVIRONMENT REQUIREMENTS

- The installation environment must be of a suitable width: with the size and overall dimension provided in the accompanying documents check that no obstacles are present while positioning the radiographic system.
- The environment must not be exposed to explosion hazards and must not be pressurized
- Avoid installing the unit in environments where severe mechanical vibration or shocks are present

CLINICAL ENVIRONMENT CONDITIONS (OPERATING CONDITIONS)

- Temperature: 10 °C (50°F) ÷ 40 °C (104°F);
- Relative humidity: 25 ÷ 75 %;
- Atmospheric pressure: 850 ÷ 1060 hPa.

TRANSPORTATION ENVIRONMENT CONDITIONS

- Temperature: 0 °C (32°F) ÷ 50 °C (122°F);
- Relative humidity: see clinical environment conditions
- Atmospheric pressure: 500 ÷ 1060 hPa

WAREHOUSING ENVIRONMENT CONDITIONS

- See Transportation environment conditions



CAUTION - WARNING

- X-Mind Unity is for **INDOOR USE ONLY**
- If the X-Mind Unity has been stored at temperature below + 10°C for more than a few hours, time must be allowed for the device to reach the room temperature before connecting it to the mains voltage and switching it on.

3.2. REQUIREMENTS OF THE SUPPORTING WALL

- The supporting wall where the X-MIND unity is installed must be able to stand **448 Kg (987.67 LBS)** tear at every fixing point.
- Select the right type of wall anchors basing on the wall type, they also should be identical for every attachment point and always complying with the force value reported above.

 CAUTION -  WARNING

The nature and consistency of the supporting wall must be checked for stability and, if needed, must be checked also by a brickwork expert.
 Don't install the unit on walls with uncertain consistency or made with material that is not able to support the weights and the specifications described in the accompanying documents of the X-MIND unity.

3.3. REQUIREMENTS OF THE ELECTRICAL SYSTEM

- The electrical system must comply with the regulations in force.
- The electrical system must be able to supply the power and voltage required in the manufacturer's rating plate of the radiographic system (chart A)

Chart A

MANUFACTURER'S RATING PLATE	100 - 240Vac
NOMINAL VOLTAGE	100 - 240 Vac
FREQUENCY	50/60 Hz
Maximum Adsorbed Power (@ 65kV, 7mA, 2 sec)	850VA

3.4. REQUIREMENTS OF THE ELECTRIC LINE

- The electric line must be "single phase alternating" type with range 100 - 240 VAC.
- The electric line must be dedicated to the power supply of the X-MIND unity system.
- The electrical wiring must be effectively grounded complying to IEC - US NATIONAL ELECTRICAL CODE - AND CEI Standards or in any case, all local standards.
- It is essential install a 16A – 250V breaker/differential ($I_d \leq 0.03A$) switch upstream the radiographic system mains, however it is MANDATORY verifying and complying to current local standards.
- On the power supply line must be installed a mains switch, able to isolate the equipment from the supply mains.
- The power cord to be used for the power supply of the X-MIND unity should be TWO-POLE+GROUND type, section minimum 1.5 mm²/16AWG (3G1.5), 300/500 V, CSA/UL - IEC
- The power cord used must also conform to the eventual additional regulations of the country of installation.
- No other equipment should be connected to the same fused mains line as the X-MIND unity.
- Basing on the length of the power supply line: See (Chart B)

Chart B:

MANUFACTURER'S RATING PLATE	100 - 240Vac
NOMINAL VOLTAGE	$100 \leq V \leq 240$
MINIMUM CONDUCTOR SECTION	L-N-GND, 1.5 mm² (16 AWG) CSA/UL - IEC 300/500 V
MAXIMUM LINE LENGHT	10 m
MAXIMUM CONDUCTOR SECTION	L-N-GND, 2.5 mm² (14 AWG) CSA/UL - IEC 300/500 V
MAXIMUM LINE LENGHT	20 m



PLEASE NOTE

For longer lines, the wiring section must be increased in proportion but the cables MUST always respects the specifications indicated above.

- The independent power cable connecting the mains of the X-MIND unity light must be two-pole type of section $\geq 1,5\text{mm}^2$ (16 AWG) and complying to standards CSA/UL - IEC.
- The signal cable connecting the timer and the X-MIND unity light for external use must be two-pole type of section $\geq 0,5\text{mm}^2$ (20 AWG) and complying to standards CSA/UL - IEC.
- The cable connecting the timer and the X-MIND unity remote exposure switch for external use must be three-pole type, of section $\geq 0,3\text{mm}^2$ (24 AWG) and complying to standards CSA/UL - IEC.
- The electric line characteristics must (Chart C)

Chart C:

MANUFACTURER'S RATING PLATE	100 - 240Vac
MAXIMUM LINE VOLTAGE DROP	3%
APPARENT LINE RESISTANCE	0,2 Ω

3.5. ELECTRICAL CONNECTIONS

! WARNING

Prior to installing the radiographic system, it is advisable that all the electrical connections be laid out.

The electrical system must be suitably earthed, in compliance with IEC and American NEC standards and with the laws in force in the country of installation.

In Italy, the system must be made in a workmanlike manner and in compliance with the CEI 64-8 standard, including all collateral standards concerning premises dedicated for medical purposes

X-Ray control unit (Timer)

On the timer installation wall, suitable runs for the following electric cables must be provided, according to the installation electric diagram:

- ▶ X-Ray control unit (Timer) mains cables
- ▶ Cables connecting the timer and the X-Ray signalling lamp **X-MIND unity light** (optional) (20 AWG, CSA/UL/IEC)
- ▶ Cables connecting the timer and the **X-MIND unity remote control** button (optional) (24 AWG, CSA/UL/IEC)

! CAUTION

According to the relevant standard, the x-ray control unit must be installed in a stationary location allowing the operator to control the radiographic exposure at a fixed position.

The connecting cables between the mains and the timer must be run through the wall supporting the wall plate:

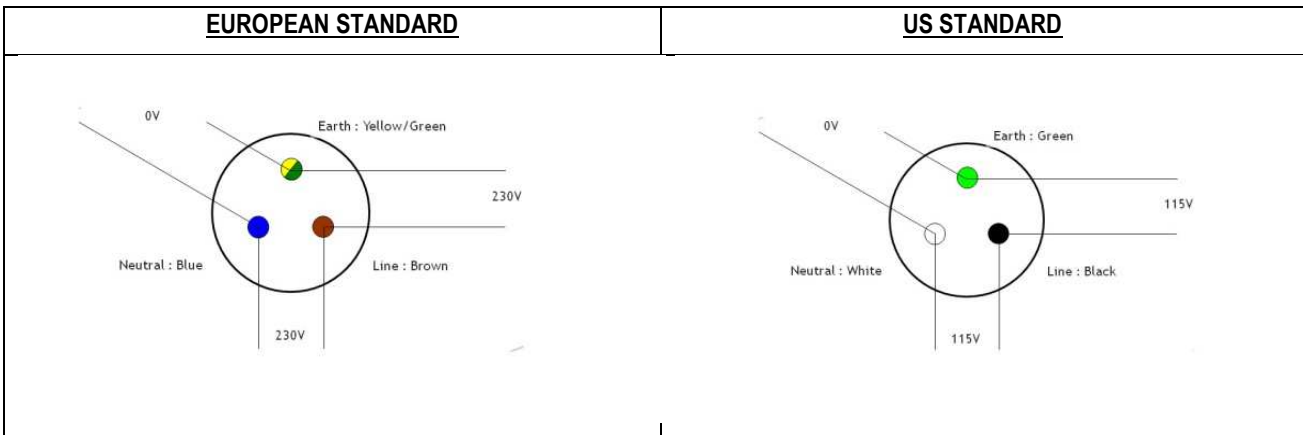

EU Line (brown): 16 AWG / US Line (black): 16 AWG

EU Ground (yellow/green) / US Ground (green) 16 AWG

EU Neutral (blue): 16 AWG / US (white): 16 AWG

4. INSTALLATION POSSIBILITIES



The equipment must be installed so that the operator can see the parameters and the armed mode indicator when releasing an exposure with either types (local or remote) the exposure switches.

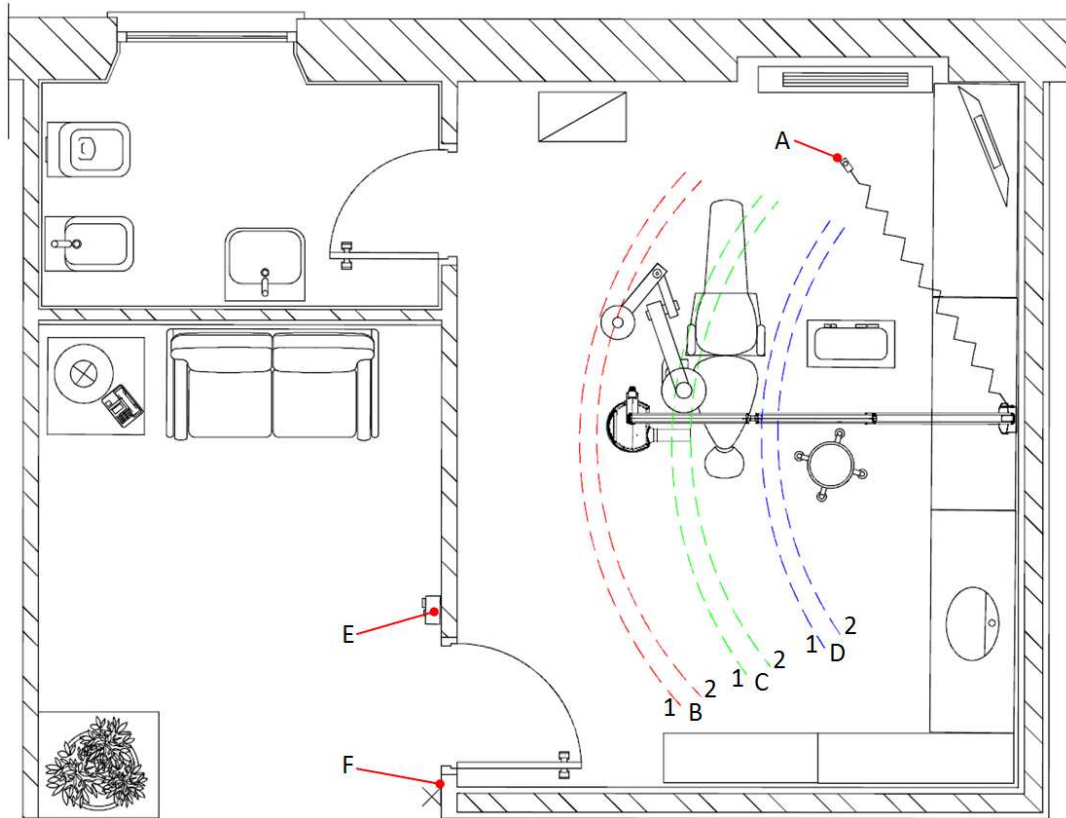







Fig. 4.1

4.1. CONFIGURATION EXAMPLES

A	STANDARD CONFIGURATION - LOCAL EXPOSURE SWITCH ATTACHED TO THE TIMER
B1	CONFIGURATION: 110cm (43") BRACKET - SHORT CONE
B2	CONFIGURATION: 110cm (43") BRACKET - LONG CONE
C1	CONFIGURATION: 80cm (31") BRACKET - SHORT CONE
C2	CONFIGURATION: 80cm (31") BRACKET - LONG CONE
D1	CONFIGURATION: 40cm (16") BRACKET - SHORT CONE
D2	CONFIGURATION: 40cm (16") BRACKET - LONG CONE
E	<u>OPTIONAL</u> - X-MIND unity REMOTE EXPOSURE SWITCH INSTALLED
F	<u>OPTIONAL</u> - X-MIND unity EXPOSURE LIGHT INSTALLED
G	<u>OPTIONAL</u> - X-MIND unity REMOTE EXPOSURE SWITCH and X-MIND unity EXPOSURE LIGHT INSTALLED

<p>OPTION E</p>		
<p>OPTION F</p>		
<p>OPTION G</p>		

4.2. OVERALL DIMENSIONS

The following figures give the overall dimensions of the possible configurations allowed, depending by the configuration that has been ordered:

4.2.1.FRONT VIEW (REST POSITION) - BOTTOM MOUNT

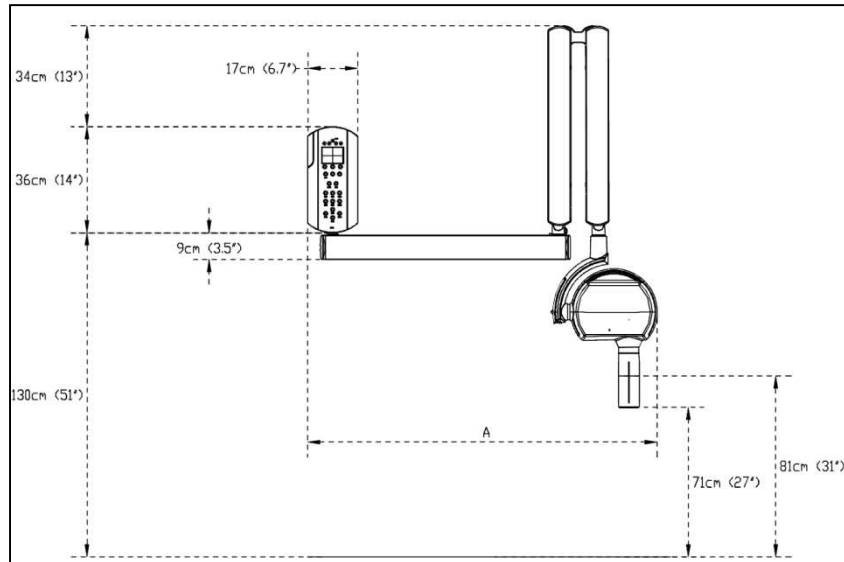

Fig. 4.2

A	
40cm (16") bracket	79cm (31")
80cm (31") bracket	119cm (46")
110cm (43") bracket	149cm (59")

4.2.2.FRONT VIEW (REST POSITION) - TOP MOUNT

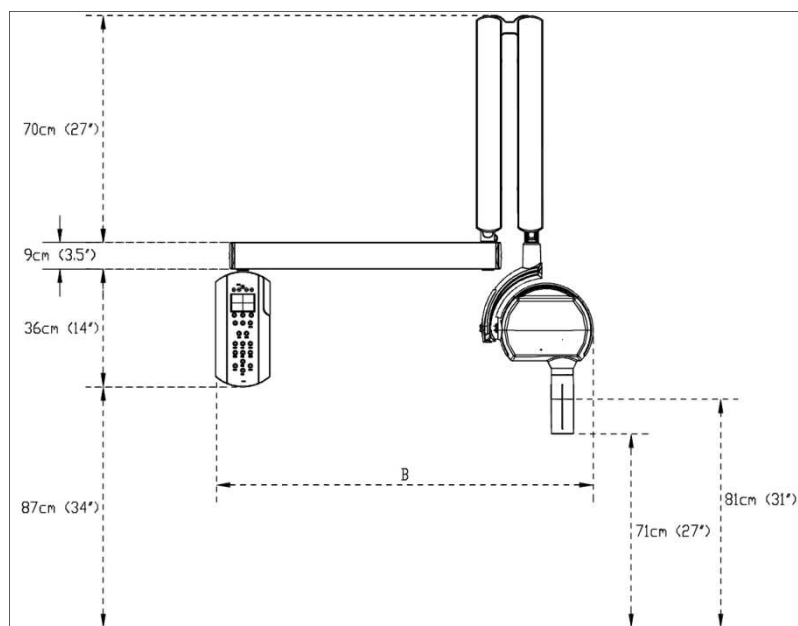

Fig.4.3

B	
40cm (16") bracket	79cm (31")
80cm (31") bracket	119cm (46")
110cm (43") bracket	149cm (59")

4.2.3.SIDE VIEW (OPEN) - TOP MOUNT

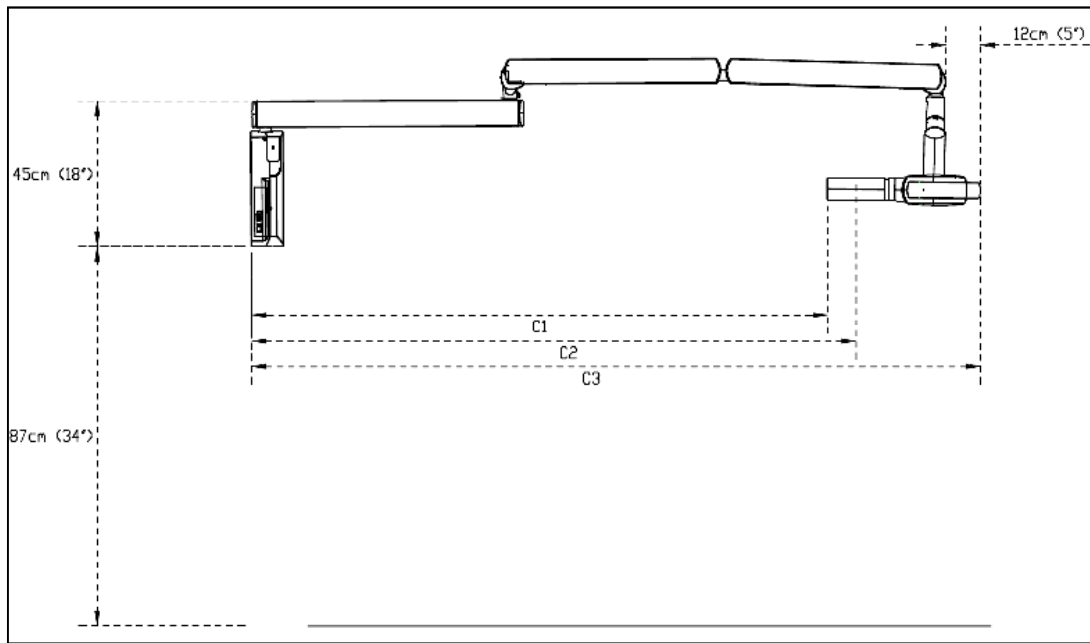

Fig.4.4

C1 - LONG CONE	
40cm (16") bracket	140cm (55")
80cm (31") bracket	180cm (71")
110cm (43") bracket	210cm (83")
C2 - SHORT CONE	
40cm (16") bracket	150cm (59")
80cm (31") bracket	190cm (75")
110cm (43") bracket	220cm (87")
C3 - FULL SIZE	
40cm (16") bracket	188cm (74")
80cm (31") bracket	228cm (90")
110cm (43") bracket	258cm (102")

4.2.4.SIDE VIEW (CLOSED) - TOP MOUNT

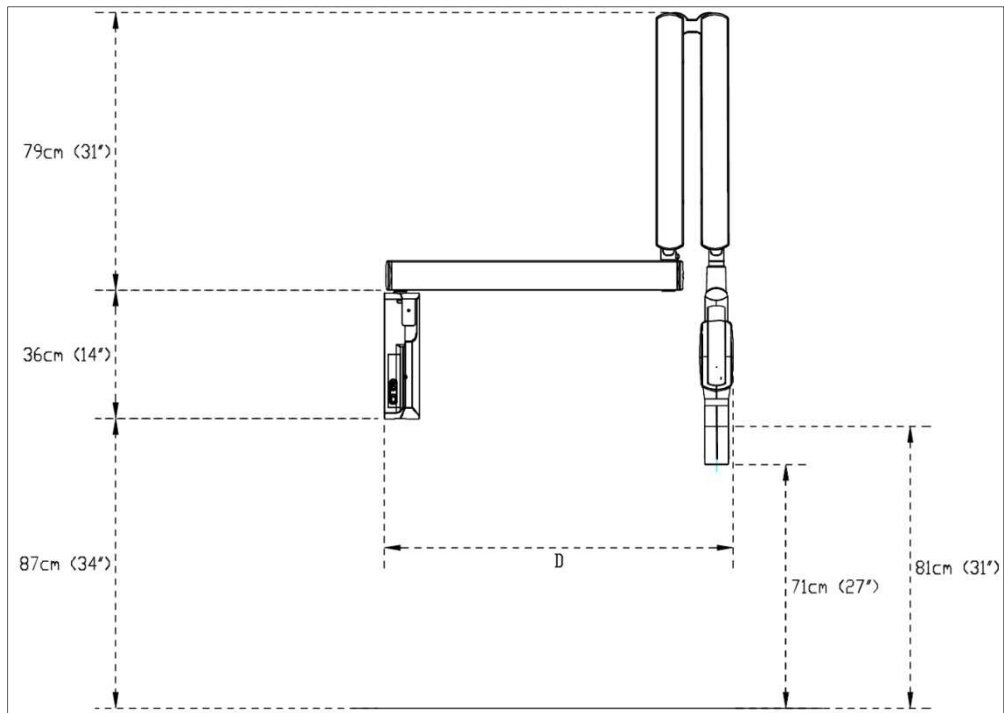

Fig.4.5

D	
40cm (16'') bracket	60cm (24'')
80cm (31'') bracket	100cm (39'')
110cm (43'') bracket	130 (51'')

4.2.5.SIDE VIEW (OPEN) - BOTTOM MOUNT

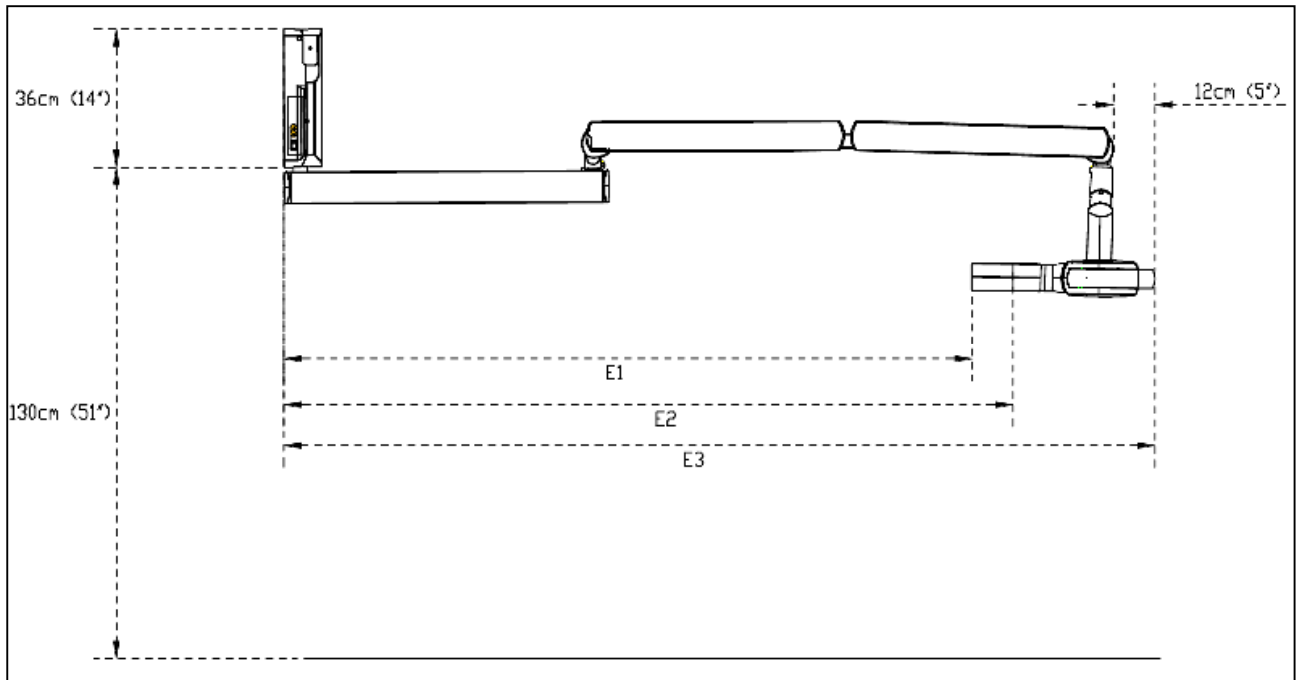

Fig.4.6

E1 - LONG CONE	
40cm (16") bracket	140cm (55")
80cm (31") bracket	180cm (71")
110cm (43") bracket	210cm (83")
E2 - SHORT CONE	
40cm (16") bracket	150cm (59")
80cm (31") bracket	190cm (75")
110cm (43") bracket	220cm (87")
E3 - FULL SIZE	
40cm (16") bracket	188cm (74")
80cm (31") bracket	228cm (90")
110cm (43") bracket	258cm (102")

4.2.6.SIDE VIEW (CLOSED) - BOTTOM MOUNT

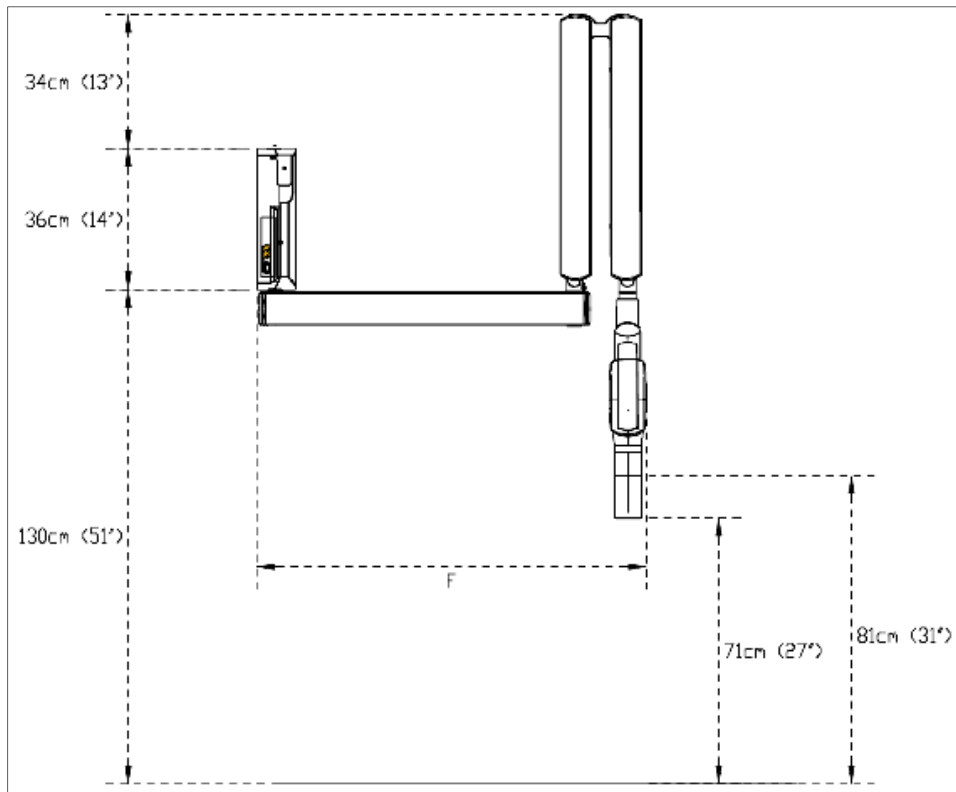

Fig.4.7

F	
40cm (16'') bracket	60cm (24'')
80cm (31'') bracket	100cm (39'')
110cm (43'') bracket	130 (51'')

5. INSTALLATION

 CAUTION

The X-MIND unity radiographic system must be installed by professionally trained technicians, who must be able to certify their work to their local state regulatory body.

 WARNING

Prior to installing the radiographic system verify that all needed requirements have been met (refer to Chapter "Installation Specifications")

 CAUTION -  WARNING

During the installation pay extreme attention of the proper connection of the all internal grounding leads of the X-MIND unity, that must be properly and safely connected. For additional information refer to the electrical and wiring schemes provided in the Installation & Maintenance Manual.

It is mandatory check the safety ground continuity with proper calibrated instruments and according to the regulations in force after the installation, before the first use of the unit or after each maintenance or repairing.

The checking of the proper electrical connections and safety grounding must be part of the periodical maintenance of the X-MIND unity device.

5.1. UNPACKING

The components of the X-MIND unity radiographic systems are properly packed within 2 boxes, as shown in the Fig. below:

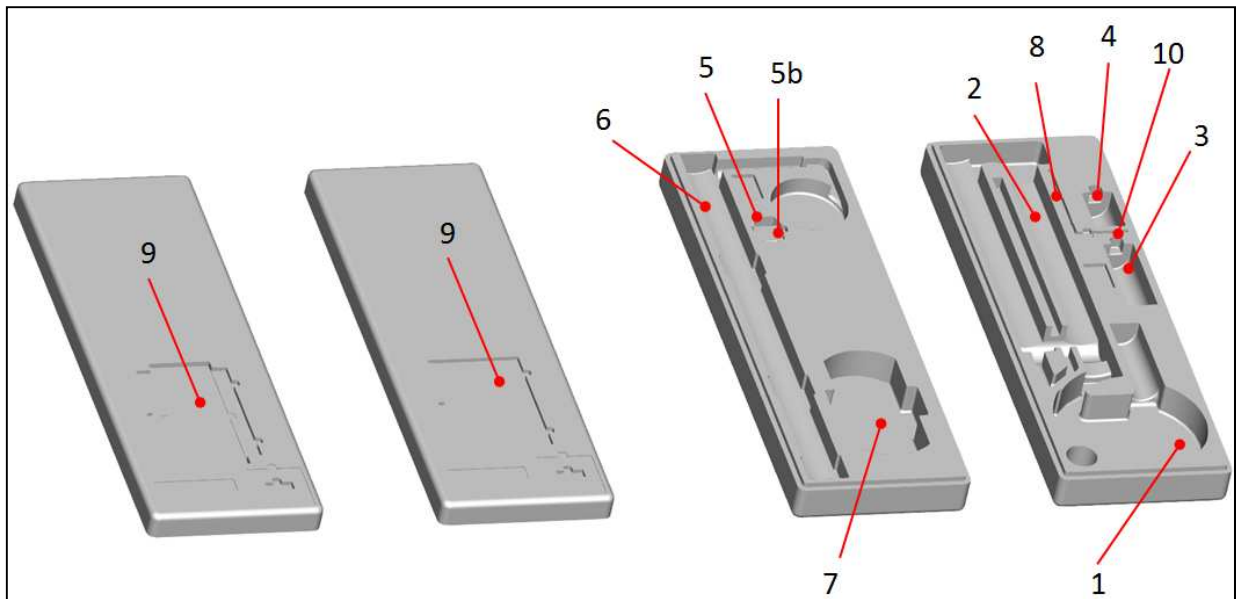

Fig. 5.1

1	X-Ray Source Assembly (tubehead) + Long cone
2	Pantograph Type Arm (Scissor)
3	Long Cone Types
4	Short Cone Types
5	Bracket cap
5b	Grease
6	Bracket
7	X-Ray Control unit (Timer)
8	Spring adjustment key
9	Quick Start Guide, Wall Template, general documents
10	Screw caps

 **PLEASE NOTE**

Prior to installation, properly check all components and check whether the product shows any visible signs of damage

 **PLEASE NOTE**

The x-ray source assembly and the pantograph arm are already connected together.

 **PLEASE NOTE**

It is advisable to store the original packaging to return the goods for repairs.

5.2. ASSEMBLING THE WALL PLATE

! WARNING

*The wall plate must **NEVER** be rotated, it must be installed with the same orientation both for TOP and BOTTOM installation.*

The only difference it is the height of mount from the floor. Refer to the overall dimension drawings for more information concerning the suggested heights.

! WARNING

*The back cover of the wall plate must be installed **BEFORE** fixing the plate to the wall, it won't be possible do that later.*

This because the 3 centering pins of back cover indicated in the pictures can be inserted in the wall plate only from the back.

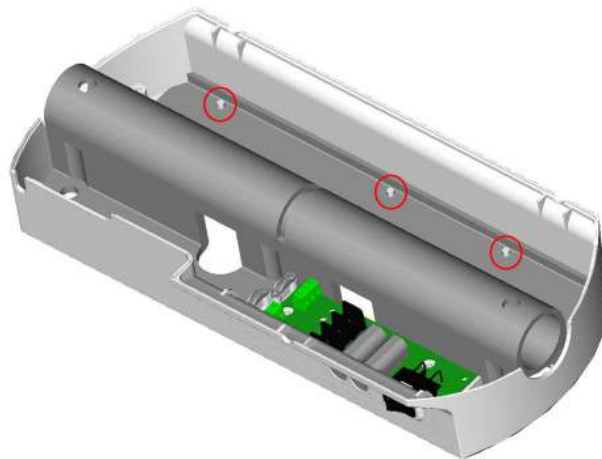

Fig. 5.2

! CAUTION - **!** WARNING

To fix the wall plate **DO NOT** use plastic or rubber anchor screws.

For cement walls, or walls built with solid or hollow bricks, use metal anchor screws Ø12 (NOT included in the supply) suitable for supporting forces and weights specified in the X-MIND unity manuals.

Anchor screws must be of maximum M8 size with hexagonal head or Allen key head.

You must choose anyway an attachment system suitable for the type of wall and capable of withstanding a tear-off force as specified in the accompanying documents of the X-MIND unity.

Check that the wall is flat and level to avoid any drift in the arm position.

✍ PLEASE NOTE

Please remove the paper template before screwing the timer to the wall board!



PLEASE NOTE

IMPORTANT: In case of new installation or replacing existing **BOTTOM** installation of a previously installed xgenus / X-mind AC or X-Mind DC family, use the holes (A) and (B).

Use holes (C) instead of (B) **ONLY** to replace a previous **TOP** installation of previous installed xgenus / X-mind AC or X-Mind DC family.

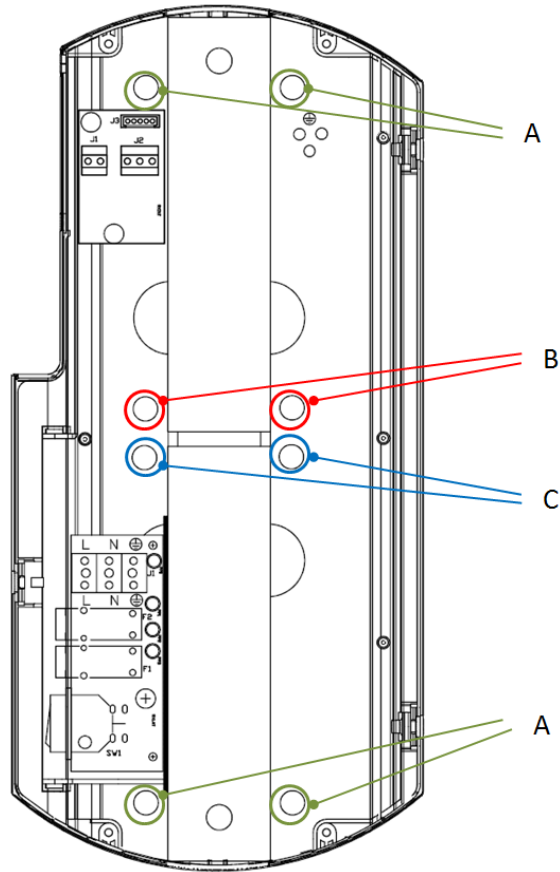
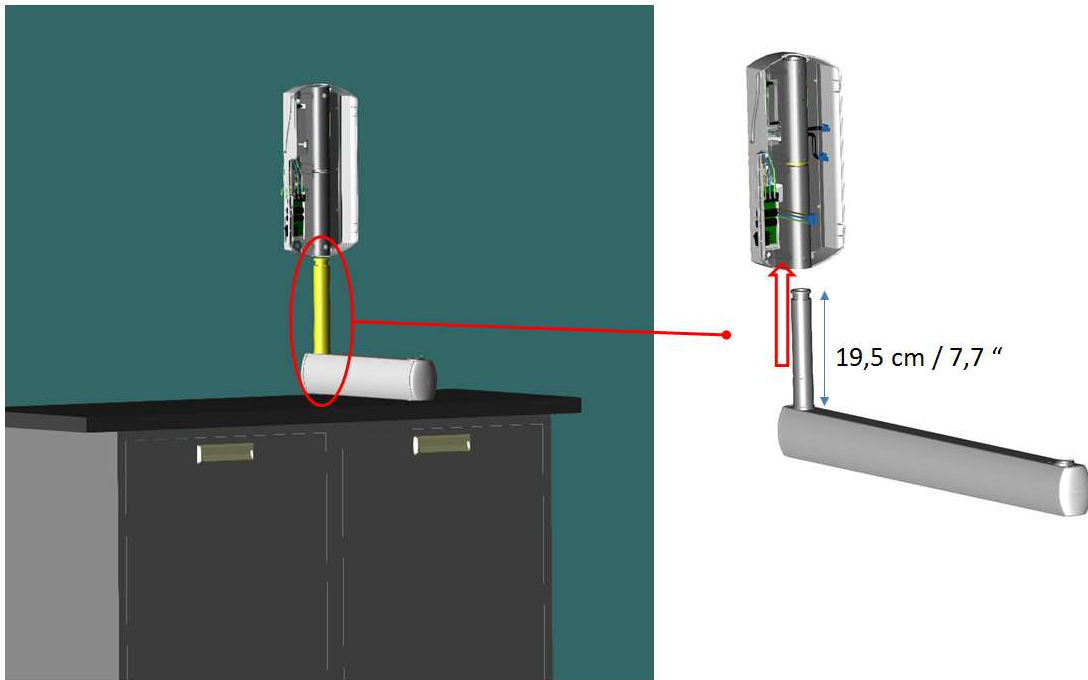

Fig. 5.3



PLEASE NOTE

IMPORTANT: In case of installation over furniture please consider enough space to insert the bracket pin, otherwise assemble the bracket to the wall plate before fix it to the wall.



ASSEMBLY INSTRUCTIONS (Fig. 5.4-5.6)

1. Remove the X-Ray Control Unit (timer) plus wall plate plus drilling template assembly from the packaging.
2. Start to disassemble the wall plate from the timer unscrewing the four screws **(5)** on the front cover and lift it to remove the cover **(4)**.
3. Then unscrews the four screws **(3)** of Control power board box **(2)**.
4. At this point the wall plate and timer back cover **(1)** can be installed to the wall.

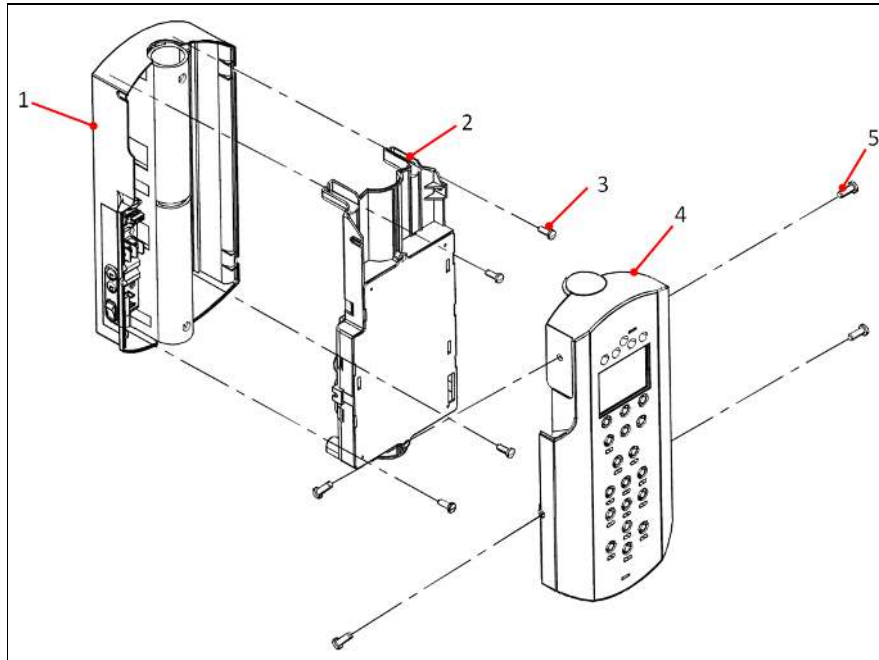

Fig.5.4

Once the assembly has been disassembled according to the above, position the drilling template (A) on the radiographic system installation wall, at the required height:

130cm (51.18 in) from the base for **BOTTOM MOUNT** / 87 CM (34.25 IN) from the base for **TOP MOUNT**

! WARNING

Do not use the wall plate as a drill template, you could damage the PCBs installed in it.
Always use only the paper template provided in the official packaging of the X-MIND unity to perform the wall drilling.

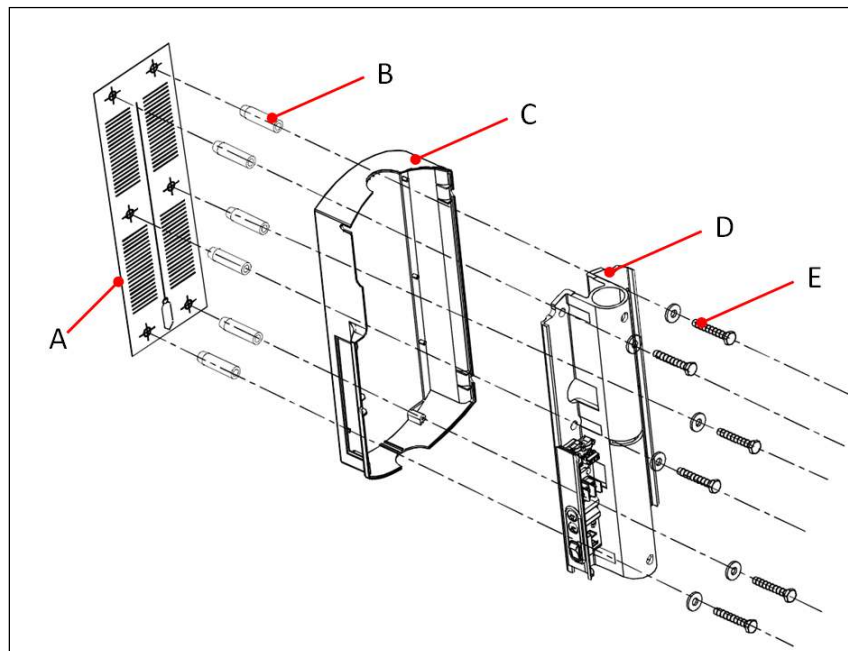

Fig.5.5

2. Fix the template with adhesive tape
3. Check the holes in order to obtain the proper verticality and alignment with the floor, using a plumb line
4. Mark the fixing holes of the wall plate
5. Also mark the holes for the electric cables connecting mains, optional exposure key or external light to the timer



PLEASE NOTE

To prevent any flaking of the dry wall and to control the center distances between the holes, it is advisable to start drilling with a tip $\varnothing 7$ mm / (9/32") , increasing this measure gradually

6. Drill the fixing holes
7. Remove the template **(A)** and insert the suitable anchor screws **(B)**, according to the wall characteristics.
8. Insert the timer back cover **(C)** to the wall plate **(D)** using centering pins.
9. Lean the assembly **(1)** to the wall in correspondence of the holes.
10. Hold the assembly **(1)** to the wall and insert the screws **(E)** with the relevant washers, then tighten alternately.
11. Make sure that supply mains cables, remote exposure key (X-MIND unity ECB) and external light (X-MIND unity light) are passing through the right hole. **(Y)**
12. Check that the assembly (wall plate + timer back cover) **(1)** is steadily fixed to the wall.



PLEASE NOTE

If the wall is not perfectly leveled, put a suitable shim between the wall and the wall plate to prevent any possible deformations

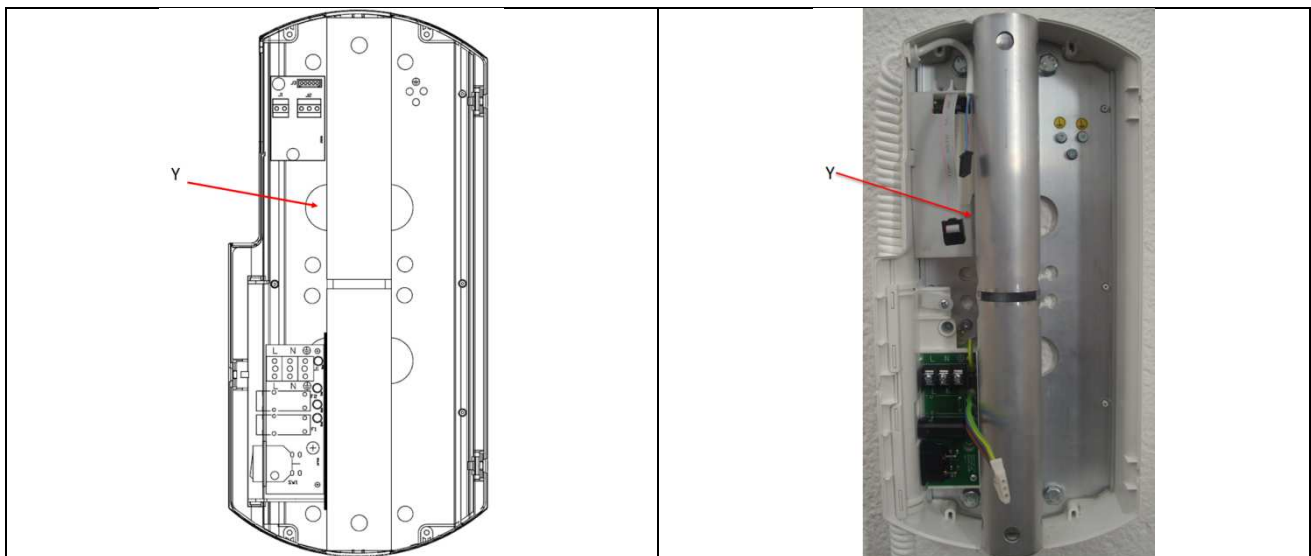

Fig.5.6

5.2. ASSEMBLING THE HORIZONTAL BRACKET

All the types of horizontal bracket available are already provided with the ground internal wiring.

A ground cable provided with ring for protective ground connection is connected at the bottom of the bracket and it must be routed and connected on the wall plate as indicated in the following instructions contained in the manual.

BRACKET PREPARING INSTRUCTIONS

Take out the bracket from the box and disassemble it as shown below, in order to have access to the cables area.

The bracket cap on the scissor arm side is already disassembled.

The disassembling procedure it is the same both for TOP and BOTTOM brackets.

To disassemble the bracket cap:

1. Remove the screw cap by using a little flat screwdriver (1).
2. Remove the screw (2) by using a Metric Allen key.
3. Remove the bracket cap (3) and remove the bottom cover (4) sliding it out.

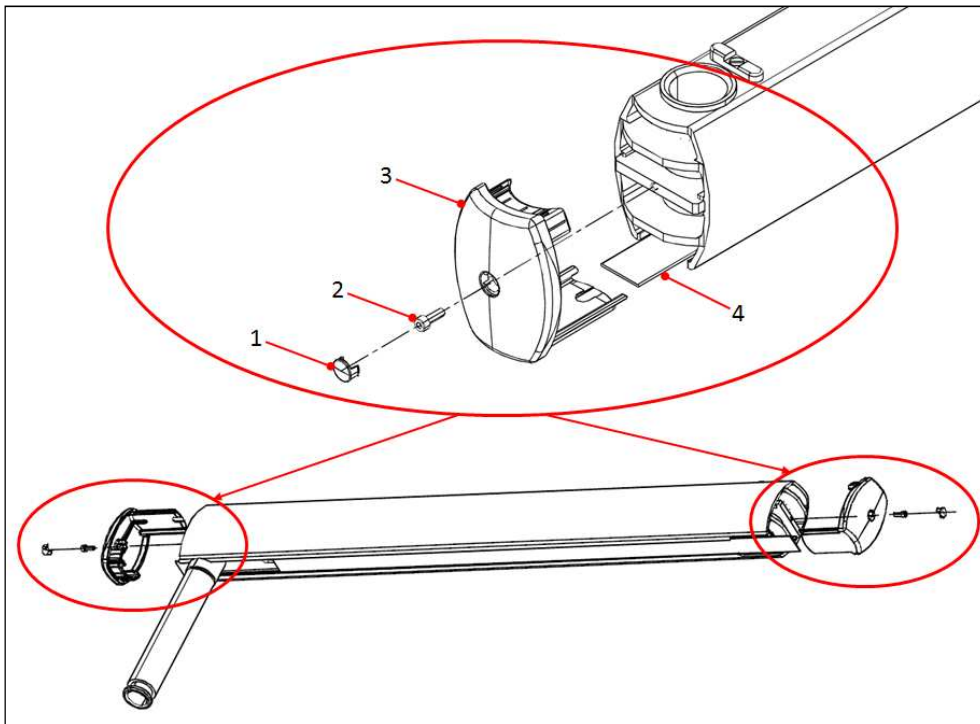
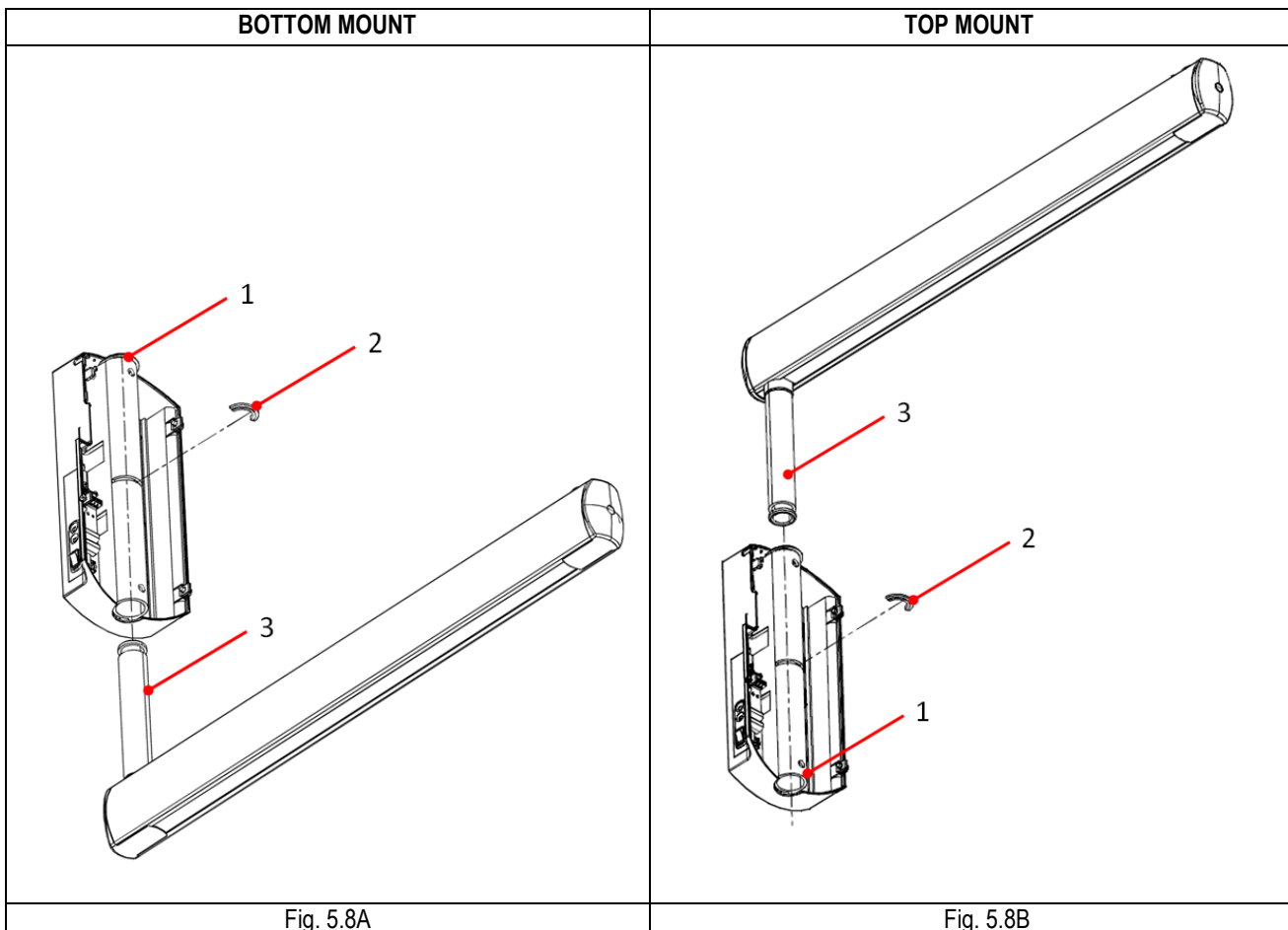

Fig.5.7

ASSEMBLING INSTRUCTIONS

1. Insert the bracket pin (3) into the wall plate (1) (TOP or BOTTOM depends from installation and bracket type)
2. Insert the half moon clip (2)



The bracket is provided from the factory with a ground cable already installed in the bracket, ready to be connected.

During the operation of insertion of the bracket tube in the wall plate hole, it is suggested first to insert the cable in the tube pushing it gently inside, then fix the bracket by the half moon clip, take the ground cable out from the holes (X) of the wall plate and then fix it properly to the dedicated ground point prepared in the wall plate.

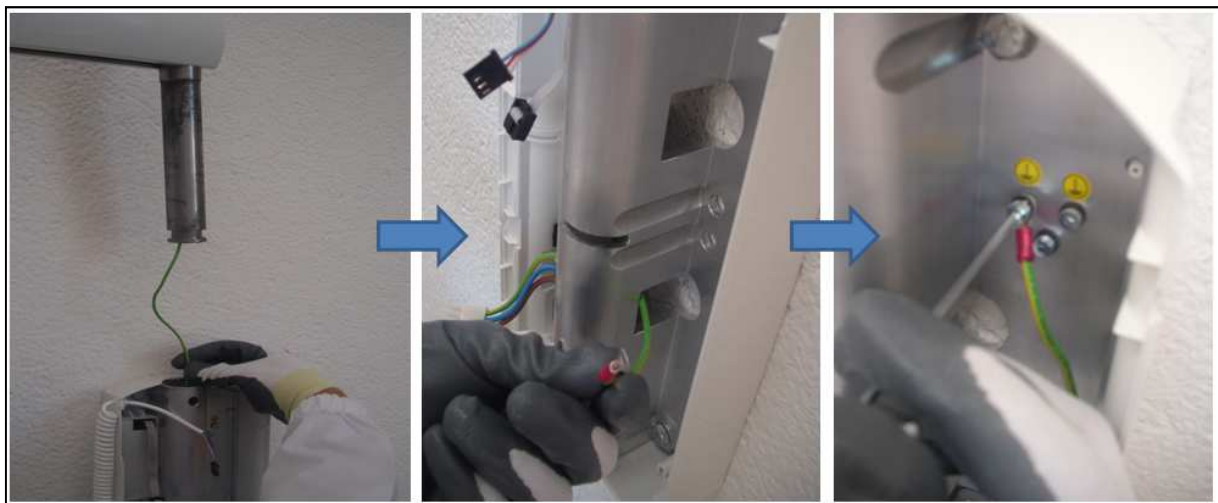

Fig. 5.9



WARNING

When inserting the bracket pin in the wall plate please pay attention to not pinch or damage the pre-installed cable. Keep them safely inside the tube until the insertion is not complete.



WARNING

Always pay attention to the routing of the cables.
When assembling the mechanical parts make sure that no cables are pinched between parts or position them in order that they can't be damaged in any way.
Do not tight too much the cables. Do not position them in a stressed position.

According to the configuration (TOP or BOTTOM), all the cables coming from the bracket must exit from the top-right holes (X) as shown in Fig. 5.10 - 5.11.

Ground and shielded cables must be connected to the ground point  by means of the dedicated screws and rings pre-installed on the wall plate.

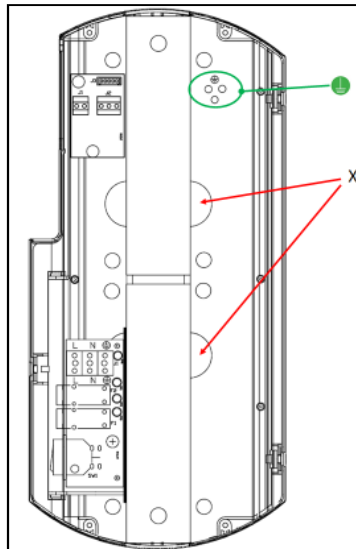

Fig. 5.10

Bracket correctly installed (example of Top Installation. The same approach, but inverted, is also valid for the bottom configuration)

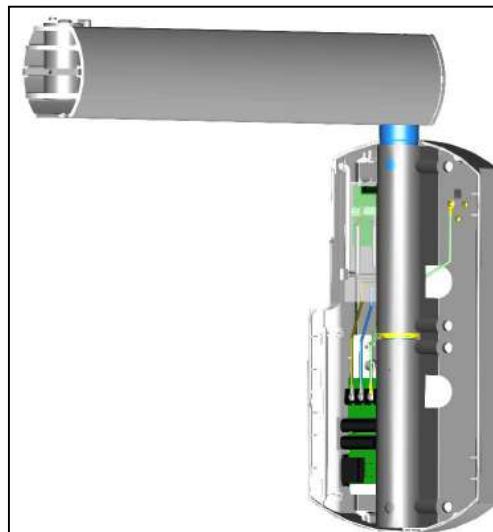

Fig. 5.11

CAUTION - WARNING

For each type of installation (TOP or BOTTOM) always ascertain that the half moon clip is properly installed in its site. Wrong installation of this part can cause injuries to operators, patients and damage the environment.

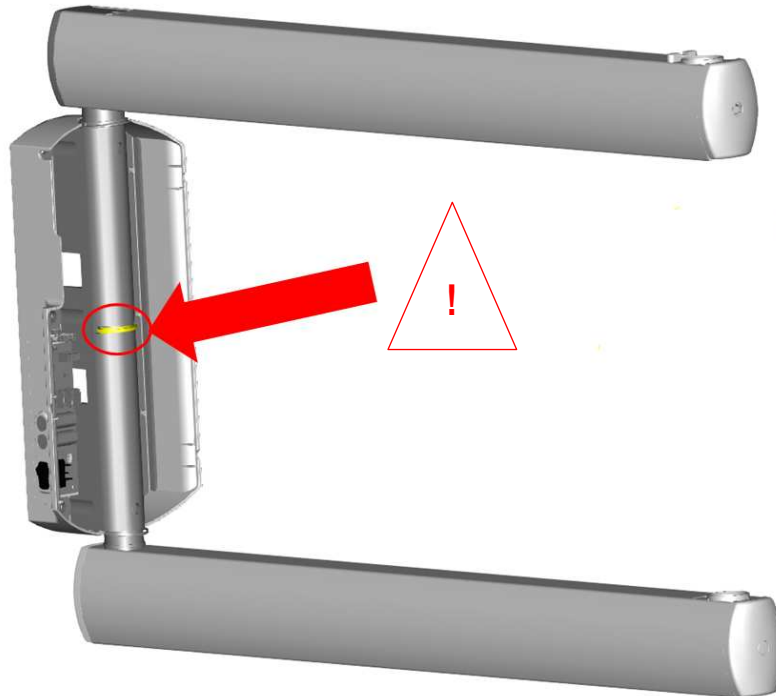

Fig. 5.12

CABLES ROUTING FOR BOTTOM INSTALLATION	CABLES ROUTING FOR TOP INSTALLATION
<p>Fig. 5.13A</p>	<p>Fig 5.13B</p>

 PLEASE NOTE

Prevent all foreign matter (dirt, dust, cement, etc.) from setting on the pin seat.
The pin must slide freely in its seat. If required, thoroughly clean and lubricate with Molikote D grease type ONLY as specified by de Götzen S.r.l. – Acteon Group. Don't try to use other type of grease.

 PLEASE NOTE

Check accurately with a spirit level instrument, the exact alignment between the bracket and the ground floor.

 CAUTION -  WARNING

The brackets are provided with a stop key  (Fig. 5.13A and 5.13B) to prevent the twisting and damaging of the internal wiring through 360° and cause electrical damage.

 PLEASE NOTE

In general the stop key is installed in order that the equipment in rest position is positioned on the right side of the installer (looking frontally the wall plate) (Fig. 5.13A).
In case the rest position is desired on the left side, the stop key must be rotated of 180° (Fig. 5.13B).

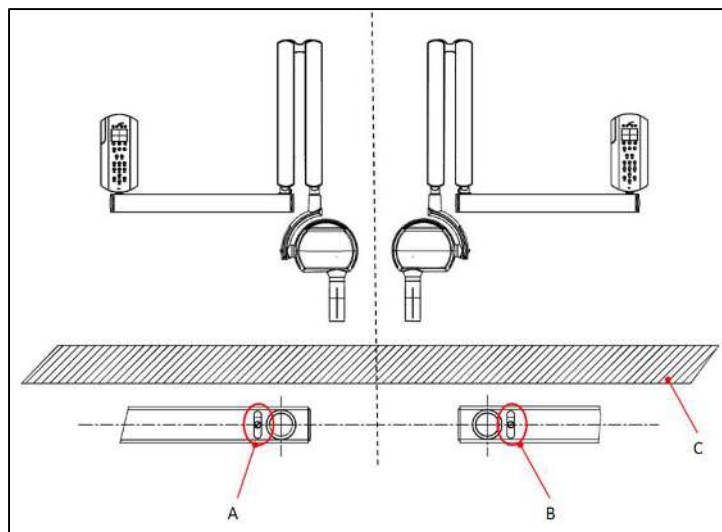

Fig.5.14

A	Stop key installation for rest position on the right
B	Stop key installation for rest position on the left
C	Wall

 WARNING

The presence and proper installation and functioning of the stop key is very important in order to prevent irreversible damage to the internal wiring, Check always the correct installation of this part.

5.3. ASSEMBLING THE SCISSOR ARM

The scissor arm is provided with the X-Ray source assembly (tubehead) already connected and installed.

 CAUTION

The spring contained in the portion of the arm relevant to the tubehead side (Arm B) is provided unloaded from the factory for safety reasons.
Anyway, when removing the assembly pantograph arm and tubehead from the package, check that the mechanical tension is fully unloaded.

 CAUTION

Pay attention when managing the assembly pantograph arm plus tubehead. This assembly is quite heavy and is an extremely delicate part.
Pay attention moving this assembly, we suggest to move that as shown below to be more comfortable during assembling operations.

 CAUTION

Risk of injury!
Do not fold up or try to fold up the scissor arm in the uninstalled state! Carefully transport the scissor arm ONLY in the unfolded state.

 WARNING

Take care of the cables exiting from tube (A), do not pinch or damage these cables.

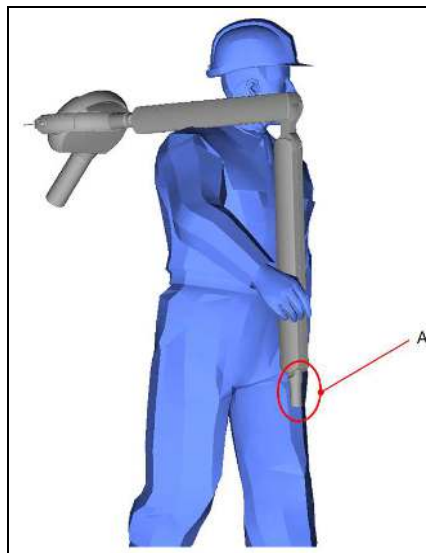

Fig.5.15

ASSEMBLY INSTRUCTIONS (refer to figures below)

1. Carefully remove the pantograph arm (scissor) from the packaging, pay attention when managing the scissor arm because the tubehead is pre-installed in factory and the whole assembly results quite heavy and very delicate.

When transporting the assembly, it is suggested to carry the scissor arm on your shoulder as shown in the picture above.

2. If not yet done, lift the screw cap (1) using a little flat screwdriver, then remove the fixing screw (2) and the bracket cap (3) by pulling it out from the bracket profile, at the end slide the bottom cover (4) of the bracket.
3. Insert the SCISSOR group wiring (7) into the bushing (5) and then the SCISSOR tube (6).
4. If required, clean the tube and the bushing and lubricate with Molikote D grease type only according to manufacturer's instructions..
5. Insert the wiring into the bracket housing (8).
6. Fix and connect the cables in the bracket as shown below.
7. Arrange the cable in the bracket and close the covers.

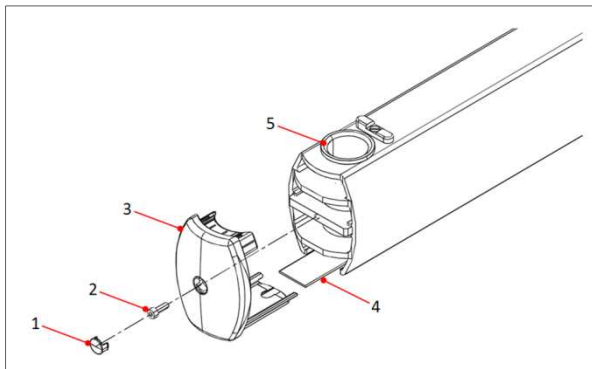

Fig.5.16

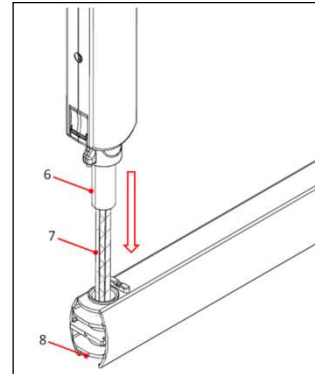

Fig.5.17



Fig. 5.18

CABLE HOUSING AND CONNECTIONS INSIDE THE BRACKET

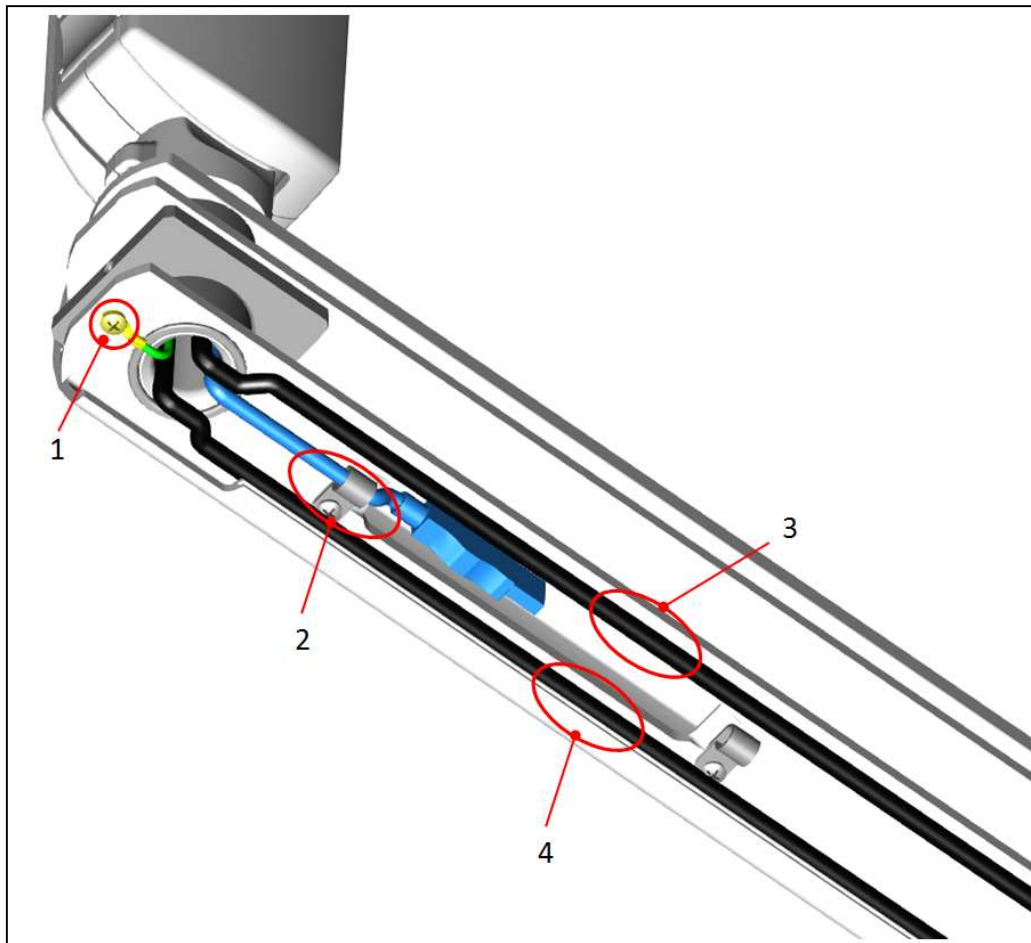

Fig. 5.19

1. Fix ground cable connection in the dedicated terminal (1) of the horizontal bracket by means of screw and toothed washer installed already provided.

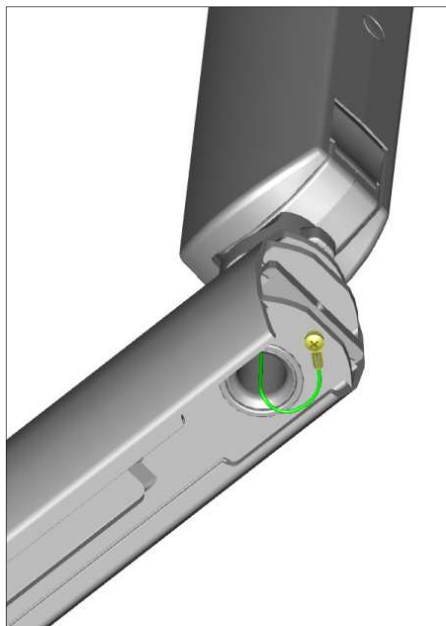

Fig. 5.20

2. Fix the USB cable using the cable ties provided in the bracket (the USB connector is protected by a plastic cap as shown below).



Fig.5.21

3. Route the COMM. CABLE in the bracket.
4. Route the POWER CABLE in the bracket.

When installing **a bracket of 40 cm (16") or 80 cm (31")**, please route cables excess inside the bracket as shown below:

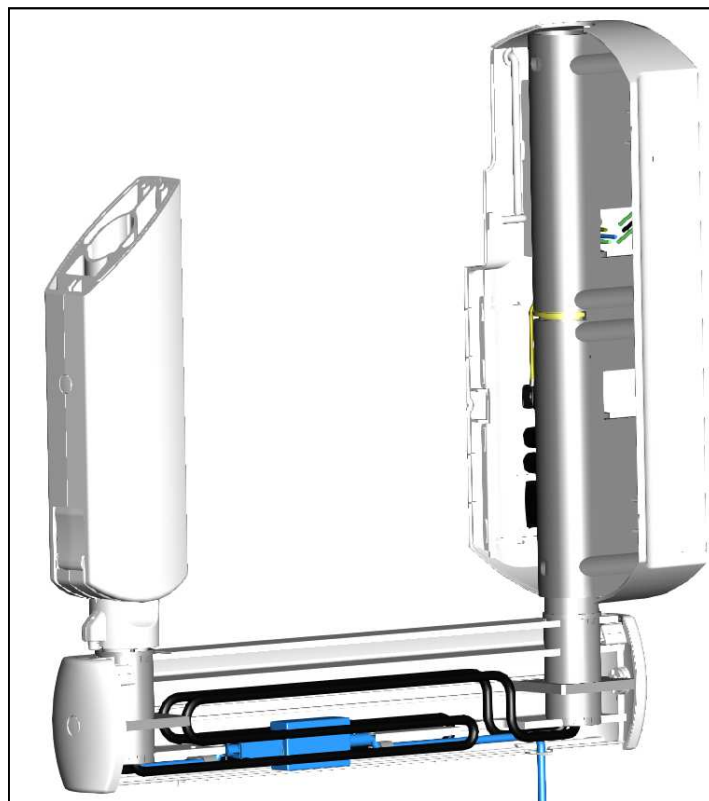

Fig. 5.22

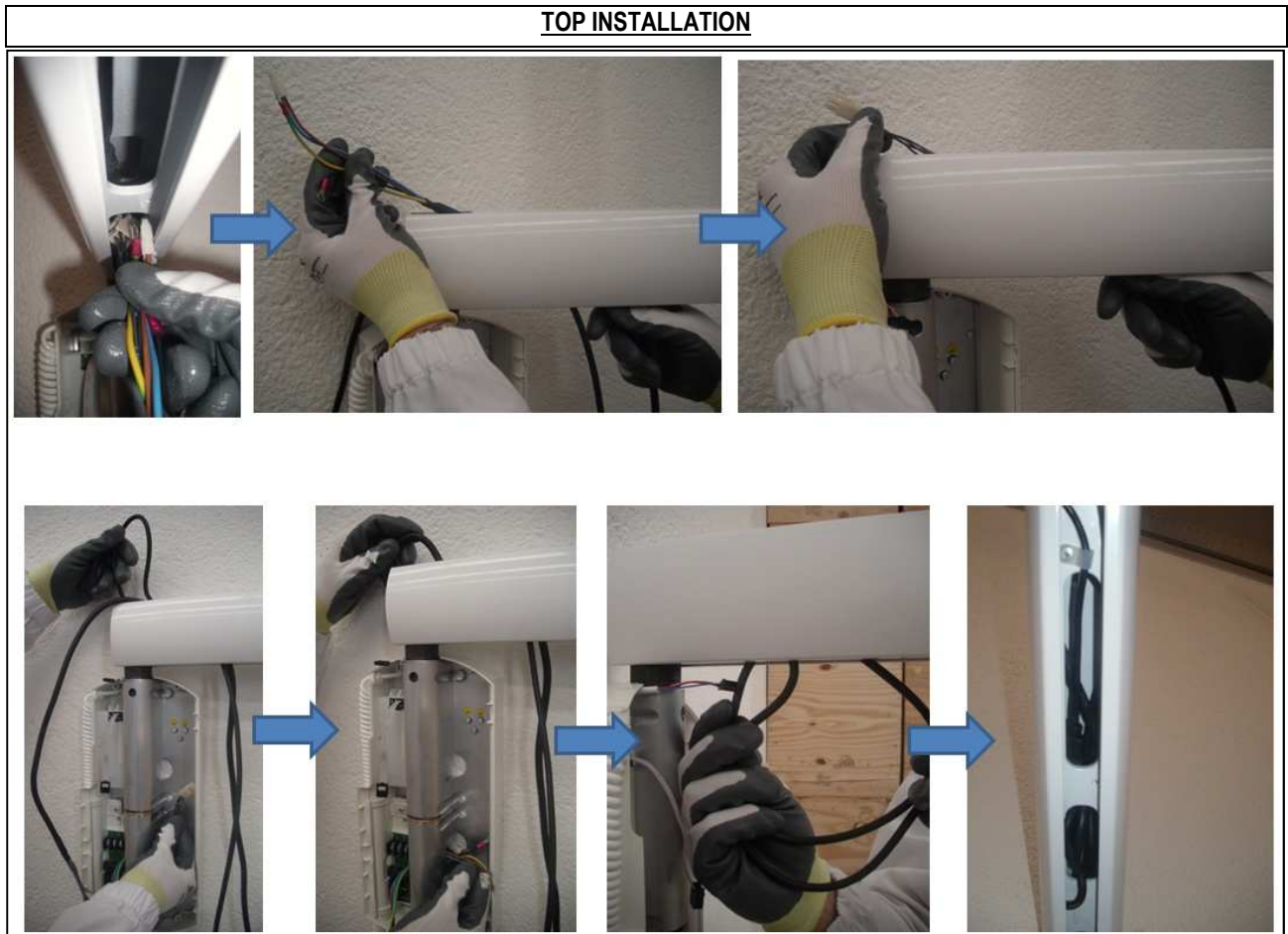
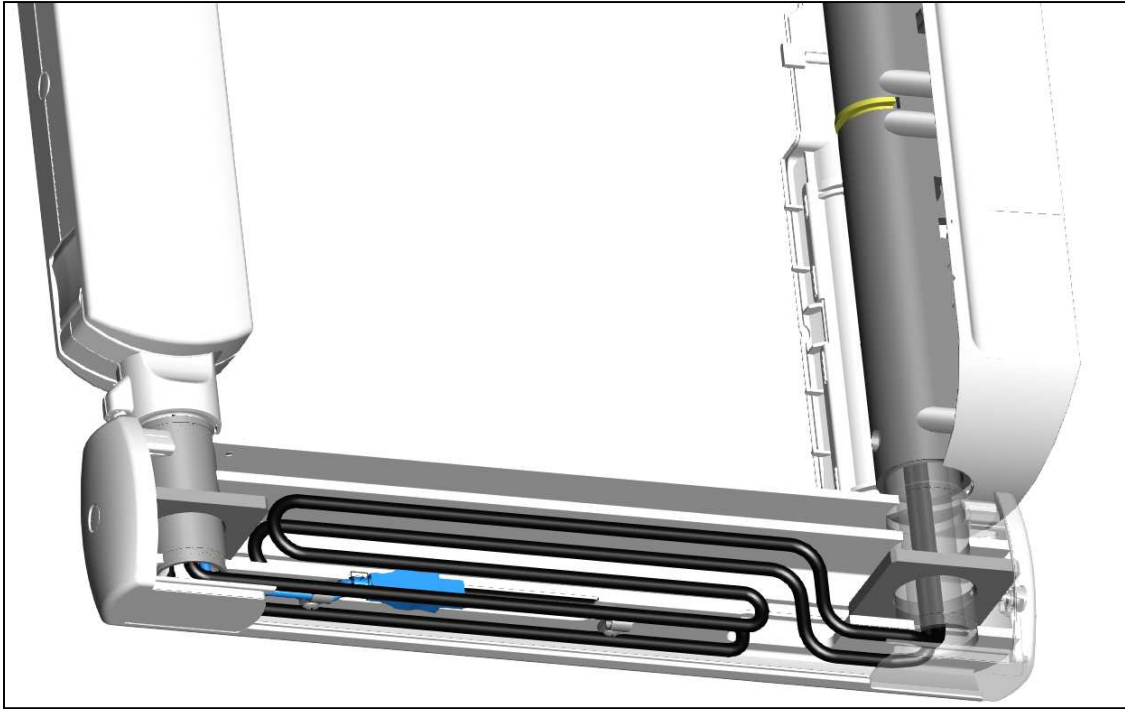

Fig. 5.23

BOTTOM INSTALLATION

In case of bottom installation, cables excess must be managed as shown above.
The only difference is that the cables won't pass through the bracket but directly inside the bracket pin.
Cables must be placed folded in the free space inside the bracket and then routed to the wall plate.



In case SOPIX/SOPIX2² Inside sensor has to be installed, follow the instructions below and the instructions provided with the accompanying documents of the Sopix/Sopix² Inside (from SOPRO-Acteon Group):

Insert the repeater in its dedicated site inside the bracket (5), connect the USB plug and fix the cable by using the dedicated cable tie (6).

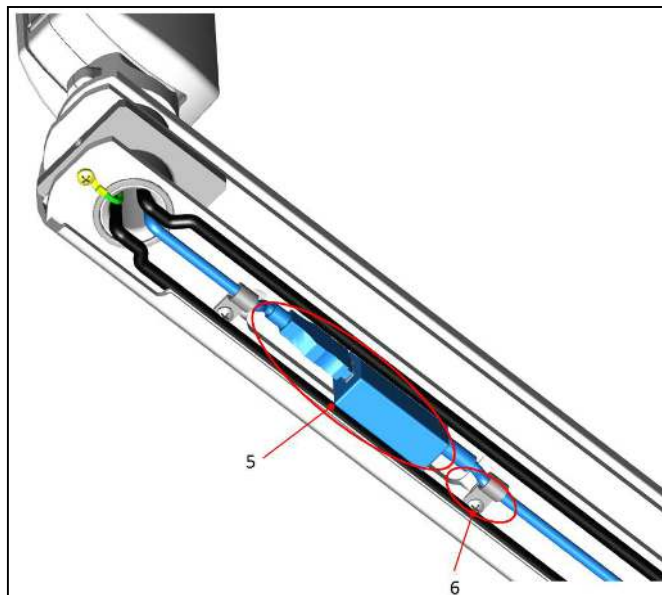

Fig. 5.24



PLEASE NOTE

Always mind to fix USB cable by means of the cable ties provided in the bracket

In case is necessary route the cable through the timer cap or bracket cap (TOP or BOTTOM), please proceed as indicated below by means of drill enlarging the hole step by step basing on the cable size.

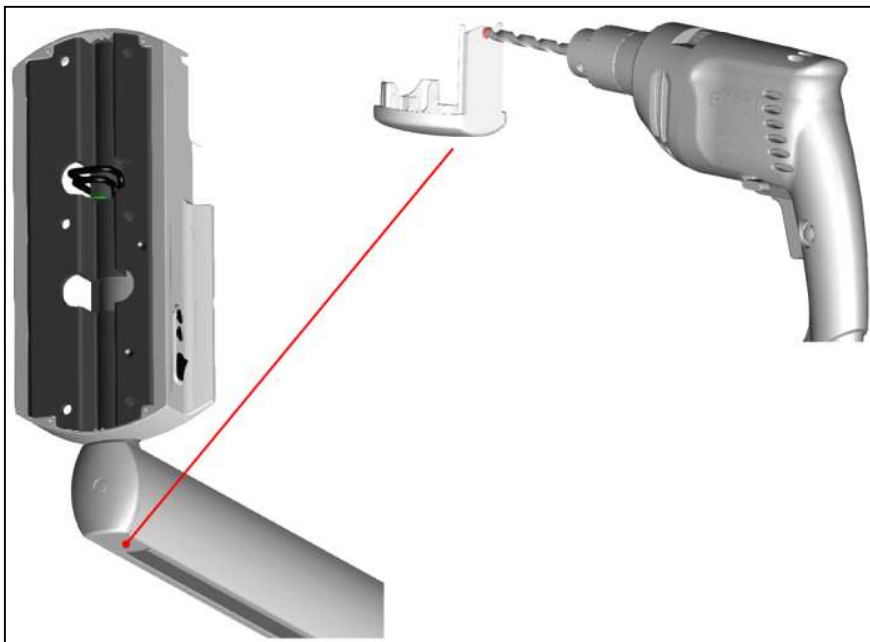
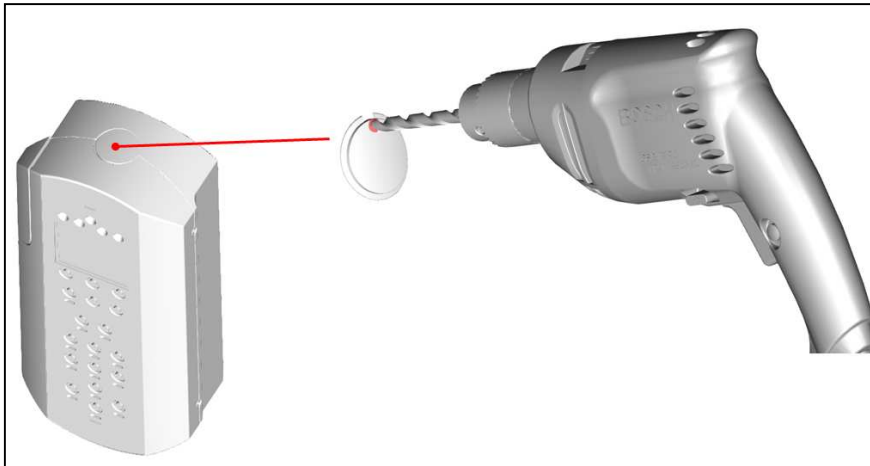

Cables routing change basing on installation types, please refer to images below for details:

TOP INSTALLATION(in the example below 110cm - 43" bracket)



Fig. 5.25

BOTTOM INSTALLATION (in the example below 110cm - 43" bracket)



Fig. 5.26

Alternative routing of the USB cable

The USB cable of the USB repeater can be routed out from the bottom side of the x-ray control unit (as shown previously) or routed in the back of the wall plate, for the routing inside the wall plate, follow the same instructions specified for routing the PWR cables and COMM. cables of the bracket (which are exiting from the scissor arm)

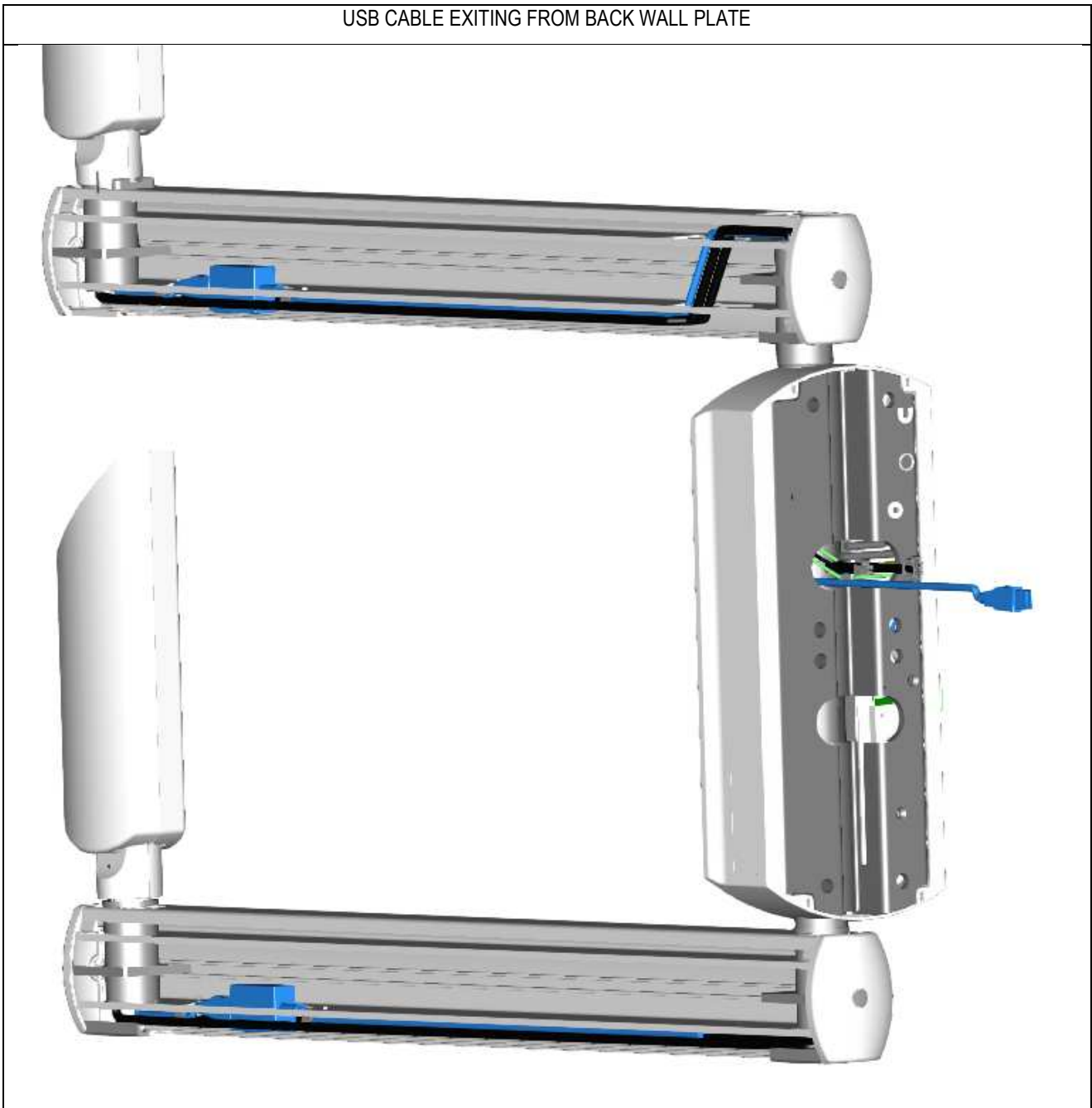

Fig. 5.27

Once the connections inside the horizontal bracket has been properly performed, remember to insert again the bottom slide cover.

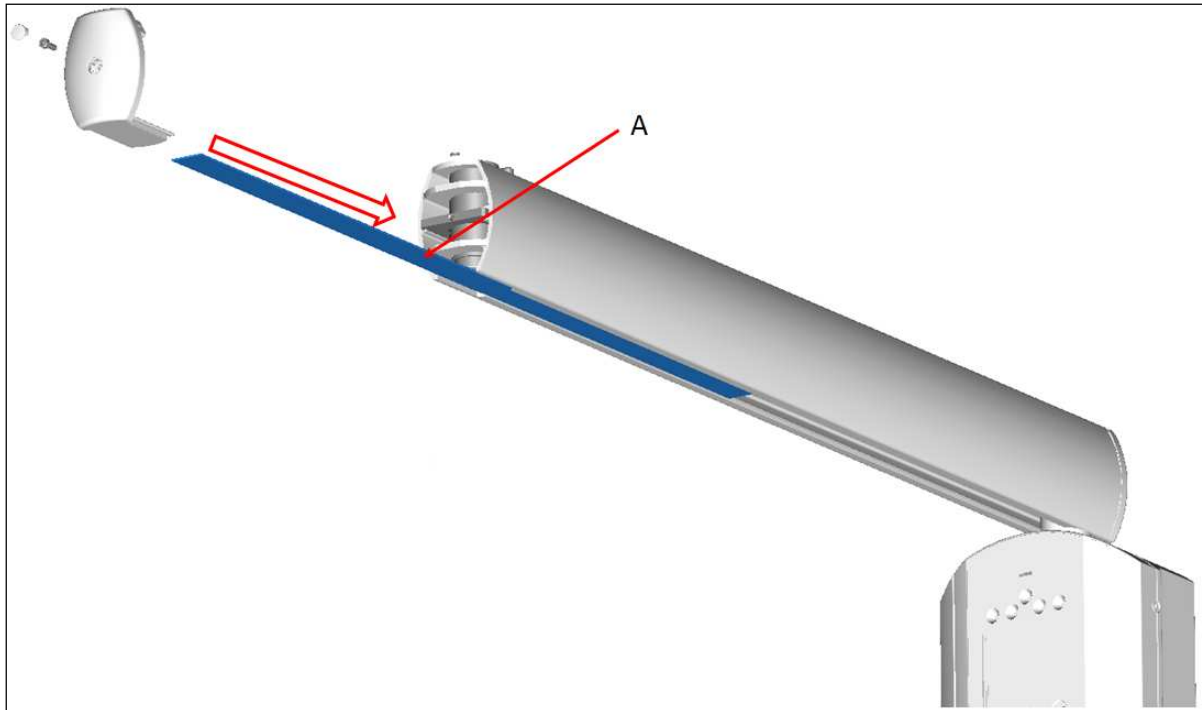

Fig. 5.28 (A= Bottom slide cover)



WARNING

Always remind to insert and properly fix again the bottom slide cover (A) inside the bracket.



WARNING

When routing the cables always be sure sure that they are adequately protected against contact with a moving part or from friction at sharp corners and edges that can damage their insulation.

BALANCING THE SCISSOR TYPE ARM

 CAUTION

The scissor arm must be adjusted ONLY WITH the x-ray source assembly assembled with it.

 WARNING

To prevent damages to the internal mechanism while performing adjustment and balancing tests, the adjustment key must not be left in place.

 WARNING

The adjustment key provided must be kept at all times for future uses and maintenance. Do not discard!

 PLEASE NOTE

To reach the adjustment screw X the arm A must be put in vertical position.
To reach the adjustment screw Y the arm B must be put in horizontal position.
The adjustment key provided can be inserted only under the above conditions.

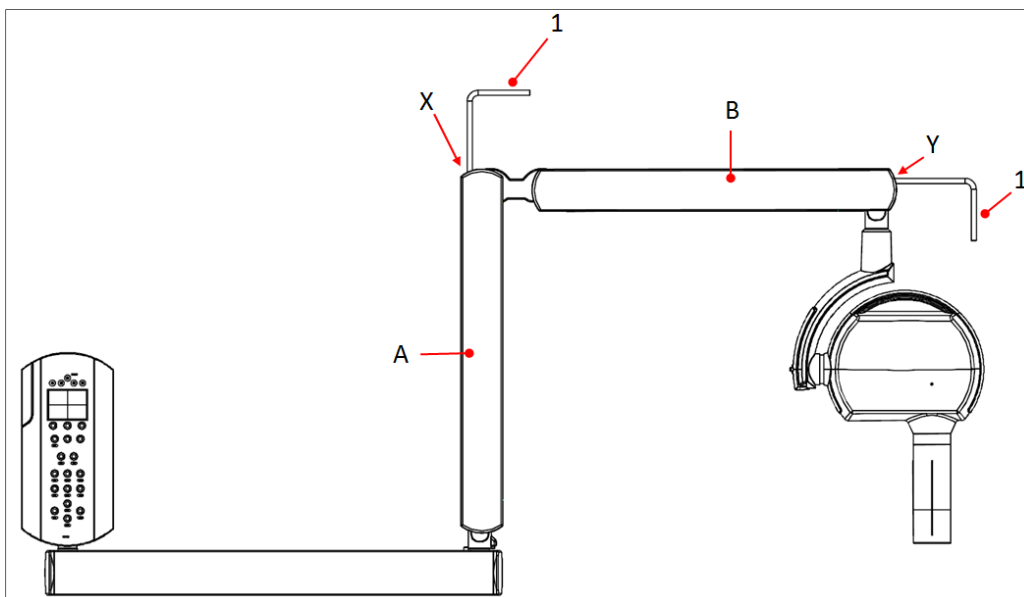

Fig. 5.29

ACCESS TO ARM "A" TO SCREW "X"

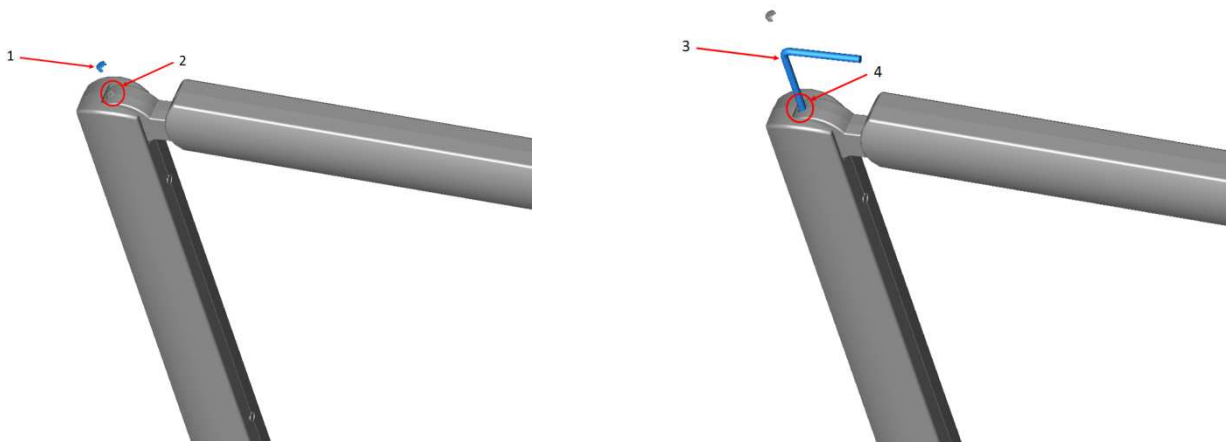

Fig.5.30

ACCESS ON ARM B TO SCREW Y

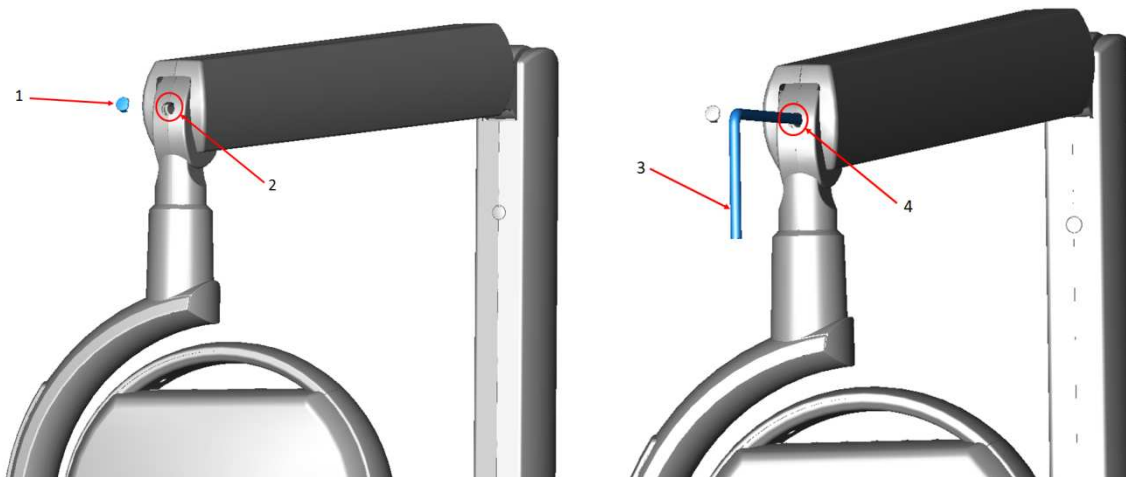

Fig 5.31

1	Screw cap
2	Screw hole
3	Adjustment key
4	Adjustment screw



PLEASE NOTE

Please always remind to assembly again the screw caps on after springs adjustment.

INSTRUCTIONS (refer to Fig. above)

1. BALANCING THE SCISSOR ARM A



PLEASE NOTE

***The SCISSOR arm is supplied with arm A spring already tensioned.
The arm B spring is supplied un-tensioned for safety reasons.***

2. BALANCING THE ARM B

- ▶ arm A vertical
- ▶ arm B horizontal
- ▶ insert the adjustment key in Y
- ▶ tension the spring by n° 22 turns
- ▶ remove the key

3. CHECKING THE BALANCING

Move arm B in various positions

IF IT DOES NOT KEEP THE POSITION



- ▶ Bring the arm B to the horizontal position
- ▶ Insert the adjustment key in Y
- ▶ Rotate the adjustment key by a half turn: clockwise if it tends to come down; counter clockwise if it tends to go up;
- ▶ Remove the key



PLEASE NOTE

Repeat the tests and adjustments until arm B is steady and stable in all positions, even when the arm A is completely extended.

4. READJUSTMENT OF ARM A

- ▶ bring the arm A to the vertical position
- ▶ insert the adjustment key in X
- ▶ rotate the adjustment key by half turn: clockwise if it tends to come down; counter clockwise if it tends to go up
- ▶ remove the key



PLEASE NOTE

Repeat the test and adjustment until the arm A is steady and stable in all positions, even when the arm B is completely extended.

5.4. ELECTRICAL CONNECTIONS

 CAUTION

Before proceeding to connections, the power supply must be turned off.

 CAUTION

Potentially lethal shock hazard!
Make sure the mains is disconnected before proceed with the following operations.

 CAUTION

For electric safety, it is essential that the ground conductors are properly connected.

 WARNING

While performing the mains connections, always respect the polarity: PHASE/ NEUTRAL.

 WARNING

While stripping the cables, pay attention to the small copper wires that may fall on the printed circuit and cause short circuits or malfunctioning.

 CAUTION

Check that the cable runs are arranged in the timer installation wall
check the compliance of the power supply with the installation specifications referring to the dedicated chapter.

 WARNING



Always observe precautions and safety measures for handling electrostatic sensitive devices in order to avoid damages or malfunctioning in the electronic boards circuitry.

 WARNING

Check that the rating data of the X-MIND unity match the power supply voltage.

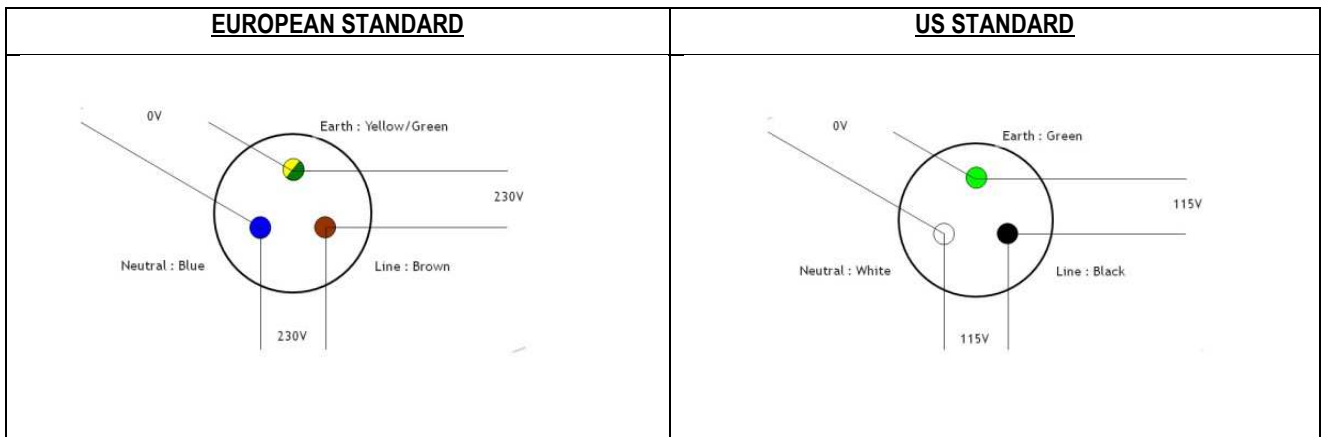

Fig.5.32

5.5.1.OVERVIEW OF THE INTERNAL PARTS OF THE TIMER

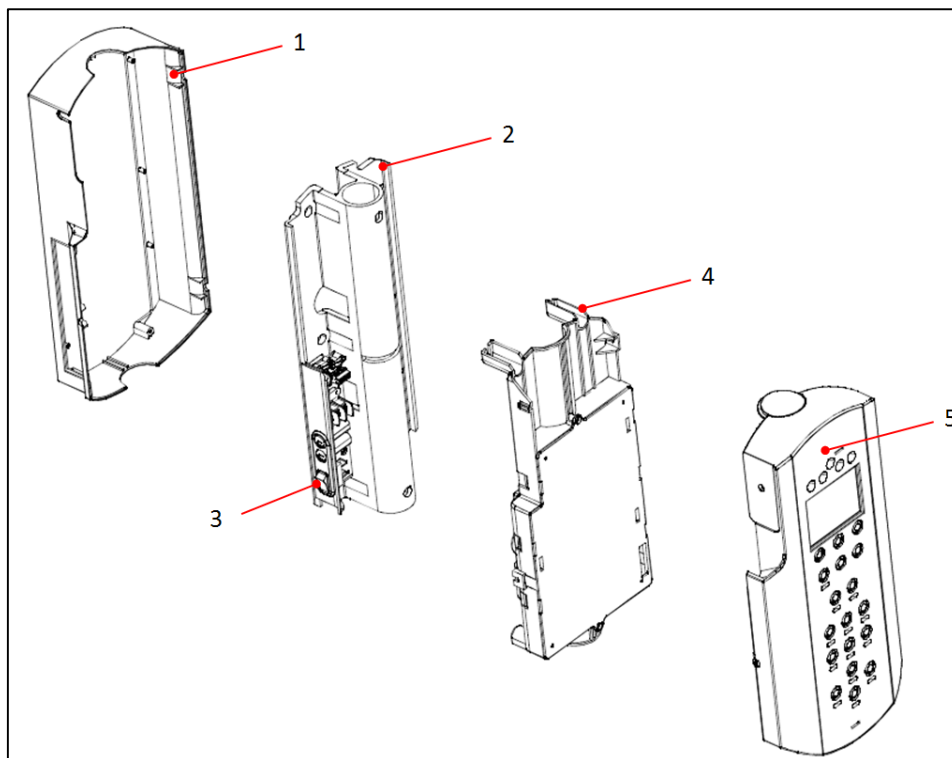

Fig.5.33

1	X-Ray control unit (Timer) back cover
2	Wall plate
3	Input power board
4	Control power board
5	X-Ray control unit (Timer) front cover and control display board

5.5.2. STEP 1 - CABLES ROUTING IN THE WALL PLATE:

Before proceed with connecting and assembling the timer make sure that the routing of the cables has been made as indicated below.

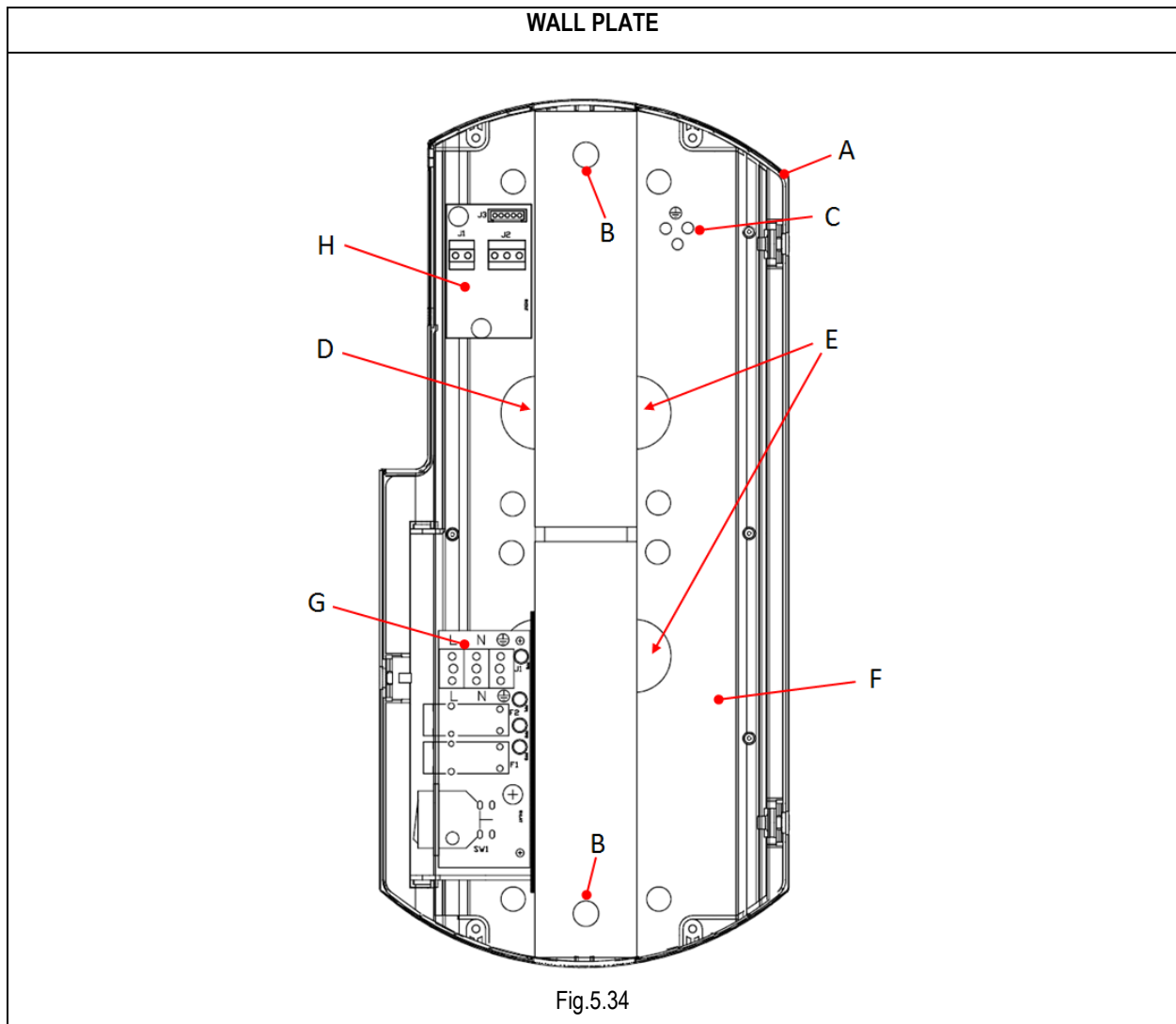

Fig.5.34

- A. X-Ray control unit (Timer) back cover
- B. Centering holes
- C. Ground screws on plate for GND distribution and shield connection
- D. Out of cables coming from wall: MAINS, LAMP, KEY2
- E. Out of cables coming from the scissor arm: Ground, POWER CABLE and COMM. CABLE
- F. WALL PLATE
- G. INPUT POWER BOARD
- H. INTERFACE BOARD

5.5.3. STEP 2 - CONNECTING INPUT POWER BOARD and INTERFACE BOARD:

Connect the cables of mains, X-MIND unity remote exposure switch and X-MIND unity light as described below before proceed assembling the next board.

Refer to the chart below for connections description.

For further details please check “ELECTRICAL SCHEME” chapter at the end of this manual.

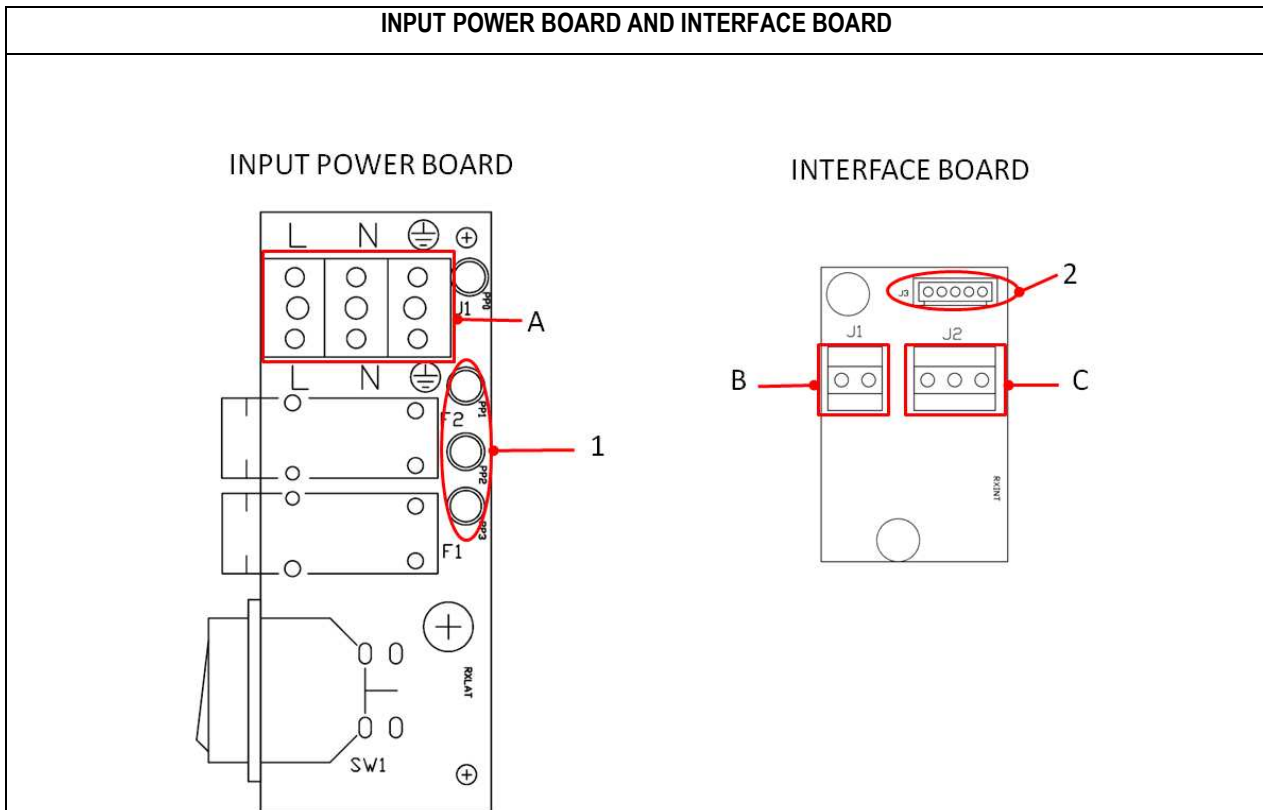

Fig.5.35

<u>IN</u>	<u>TERMINALS</u>	<u>OUT</u>	<u>CONNECTOR</u>
J1 INPUT POWER BOARD - A	<u>Power supply</u> L (phase) - N (neutral) - GND (ground)	1	TO J4 CONTROL POWER BOARD
J1 INTERFACE BOARD - B	<u>X-MIND unity external light</u> S1 (5) - S2 (4)	2 - J3 connector	TO J6 CONTROL POWER BOARD
J2 INTERFACE BOARD - C	<u>X-MIND unity remote exposure switch</u> RED (1) - WHITE (2) - BLUE (3)	2 - J3 connector	TO J6 CONTROL POWER BOARD

5.5.4. STEP 3 - GROUND POINT CONNECTION ON THE WALL PLATE:

⚠ CAUTION

It is mandatory to connect and verify the proper and safe connection of all ground cables to the dedicated ground point and throughout the entire equipment. Refer to the specific chapter relevant to the electrical and wiring schemes

Refer to the image below for connecting.

For further details about GND connection please refer to the GND routing reported in the chapter “ELECTRICAL SCHEME”

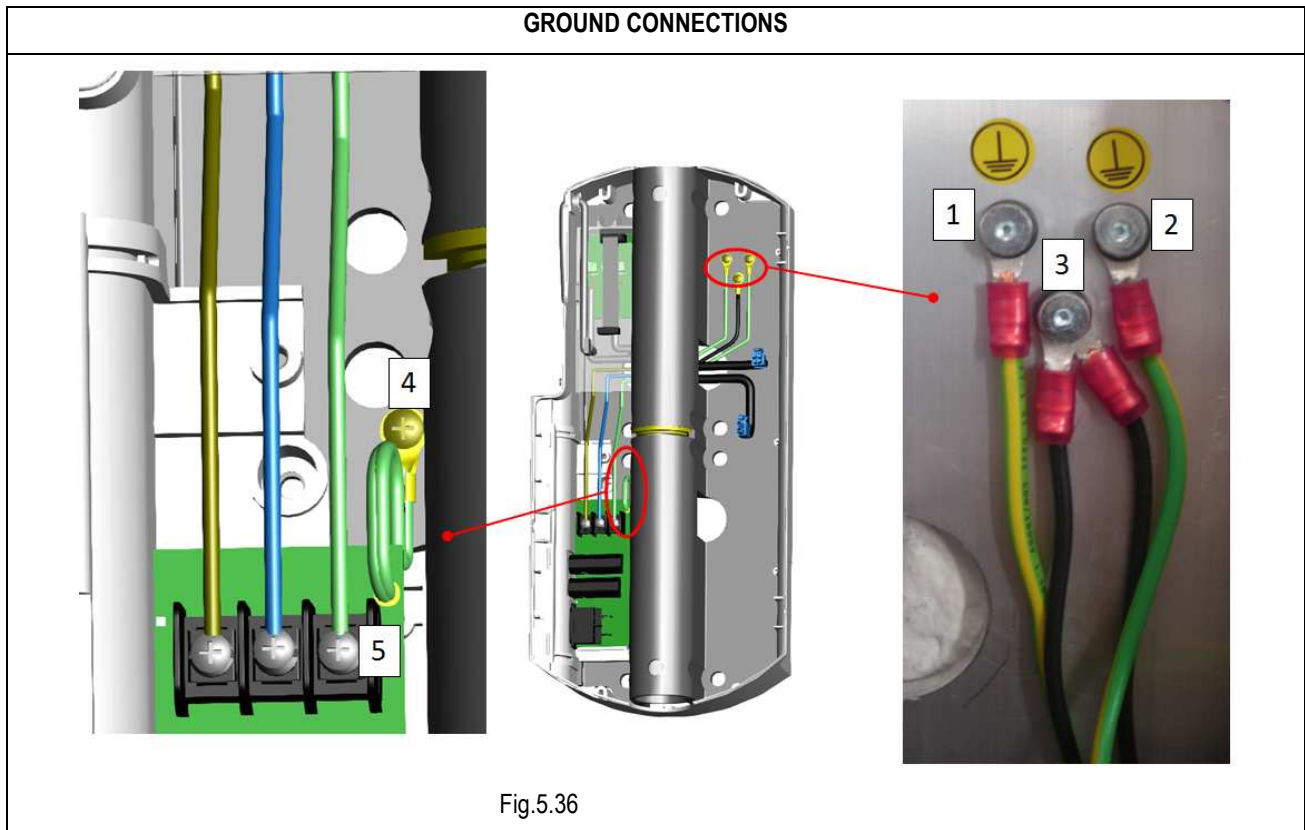

<u>CABLE</u>	<u>CONNECTION DESCRIPTION</u>
1. Ground cable coming from bracket.	GND connection between bracket and wall plate.
2. Ground cable coming from POWER CABLE.	GND connection between wall plate and tube head.
3. Shielded wires of PWR. and COMM. cables	Shielded connection to GND point on wall plate
4. Permanent connection of ground cable to INPUT POWER BOARD, it MUST be always connected to the ground point on the wall plate.	GND connection between INPUT POWER BOARD terminal and WALL PLATE.
5. Ground cable coming from mains power supply (facility electrical system).	GND connection between MAINS and INPUT POWER BOARD.

5.5.5. STEP 4 - INSTALL AND CONNECT REMOTE EXPOSURE SWITCH AND X-MIND unity LIGHT (Optional)

REFER TO CHAPTERS 6 and 7 for instructions otherwise proceed to the next step.

5.5.6. STEP 5 - CONNECTING CONTROL POWER BOARD:

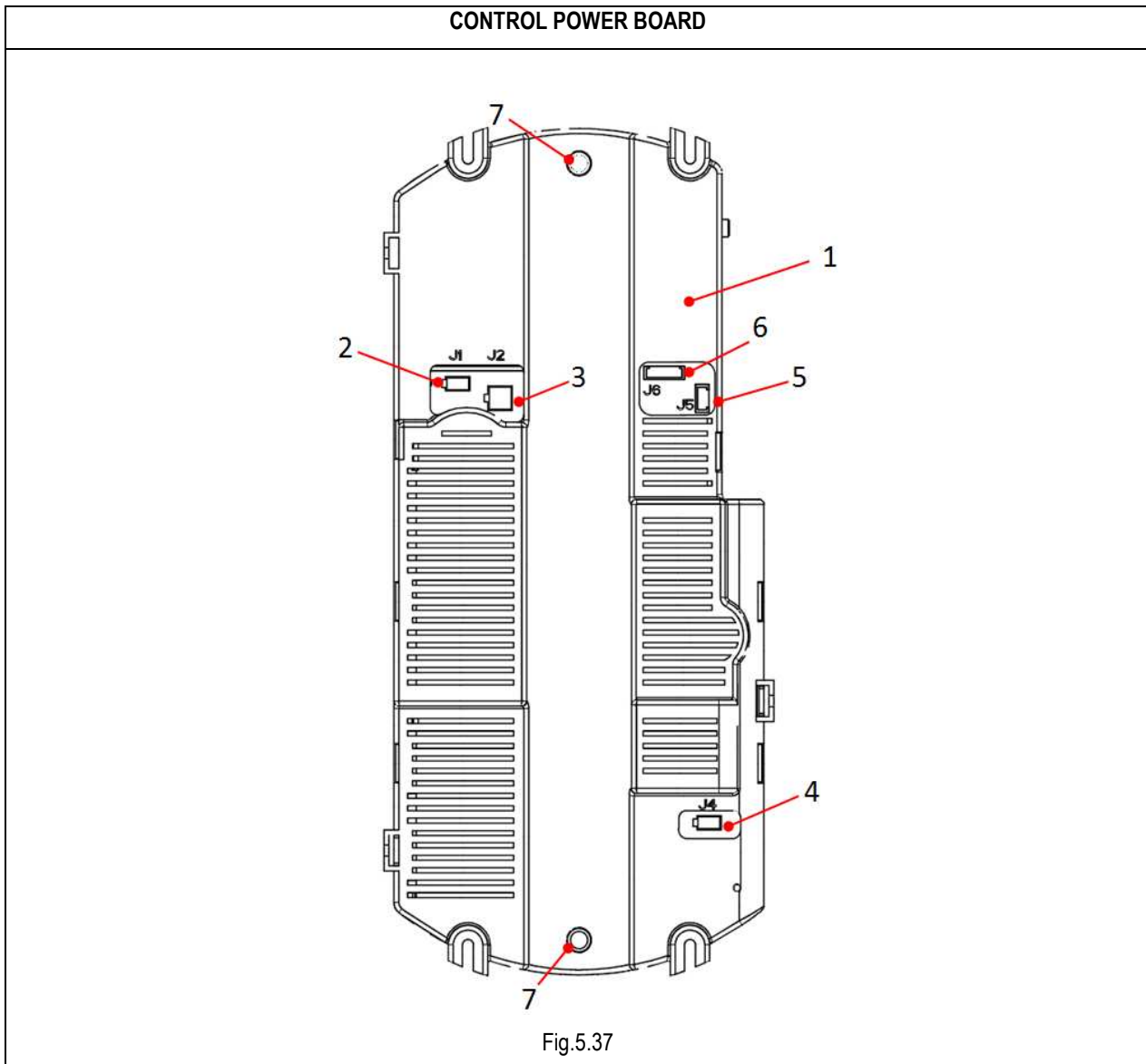

1. CONTROL POWER BOARD box.
2. J1 - POWER CABLE connector from ARM CABLE.
3. J2 - COMM. CABLE connector from ARM CABLE.
4. J4 - MAINS SUPPLY conn. from INPUT POWER BOARD.
5. J5 - Key 1 conn. from local exp switch.
6. J6 - Key 2 + Lamp conn. from INTERFACE BOARD.
7. Centering Pins.

5.5.7. STEP 6 - CONTROL BOX CONNECTIONS CHECK

Please verify that the connections in the control box comply to the scheme below.

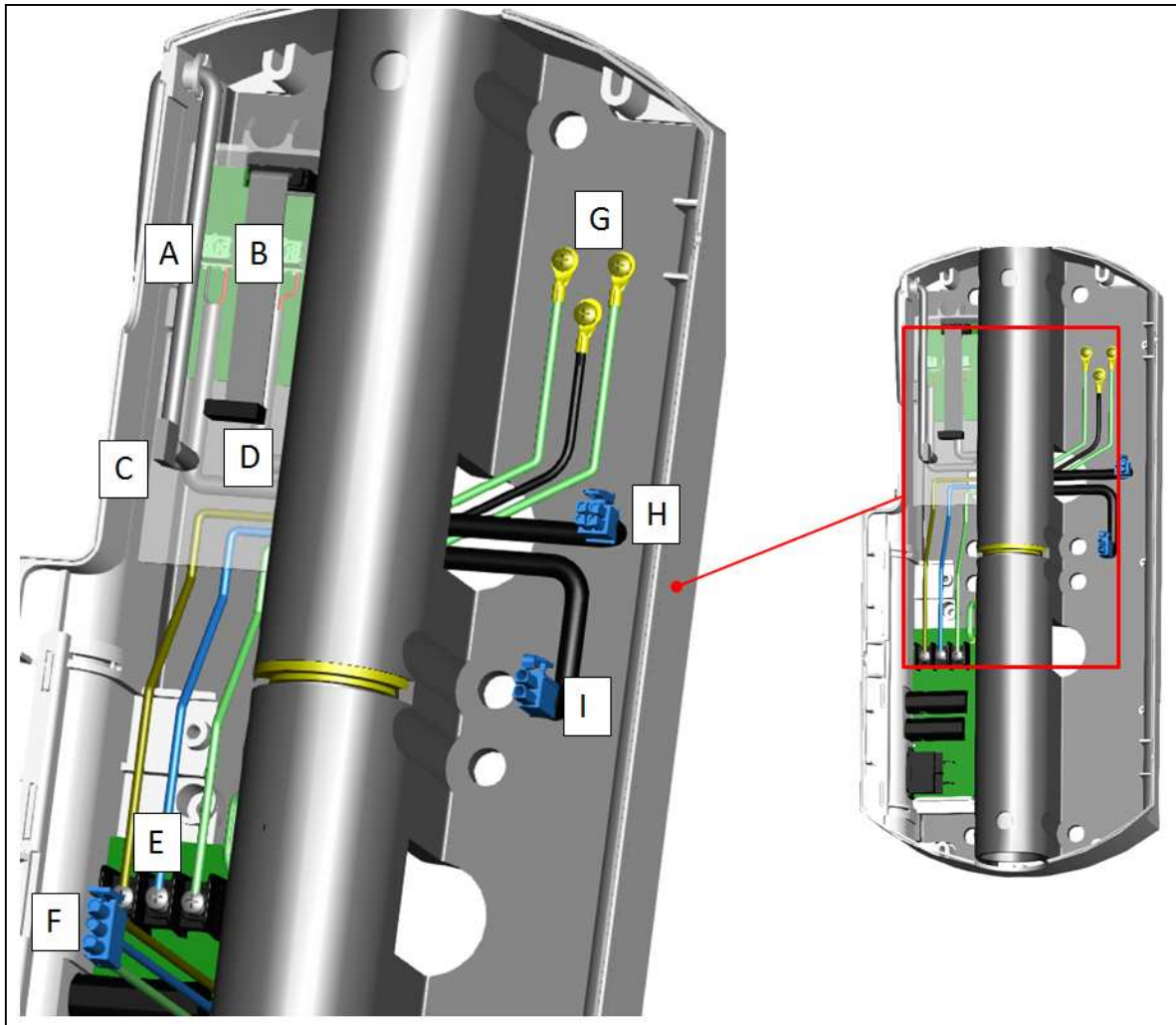

Fig. 5.38

A	Exposure lamp connection (if installed)
B	Remote exposure switch (if installed)
C	Local exposure switch cable
D	Interface board flat cable connection
E	Mains supply connection and Permanent ground connection to the plate
F	Control Power Board mains supply connection
G	Ground cables from bracket and shielded wires
H	COMM. Cable from bracket (to J2 Control Power Board)
I	PWR. Cable from bracket (to J1 Control Power Board)

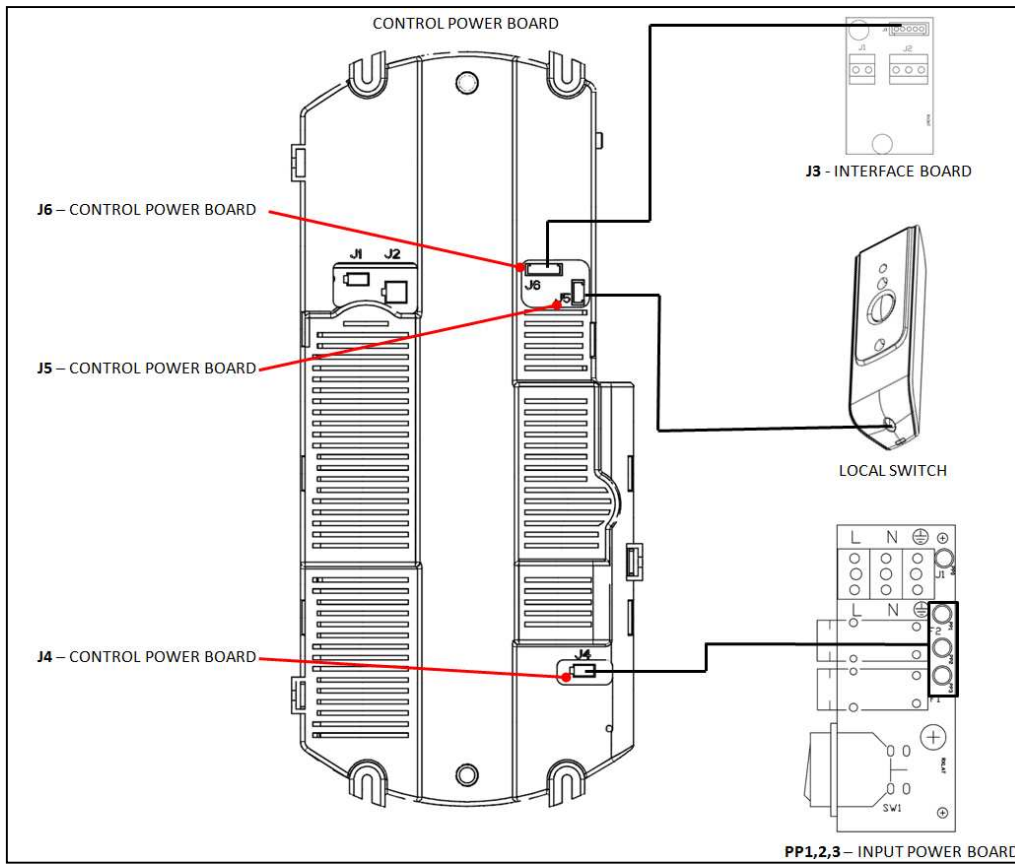

Fig. 5.39



Fig. 5.40

5.5.8. STEP 7 - CONNECTING CONTROL DISPLAY BOARD

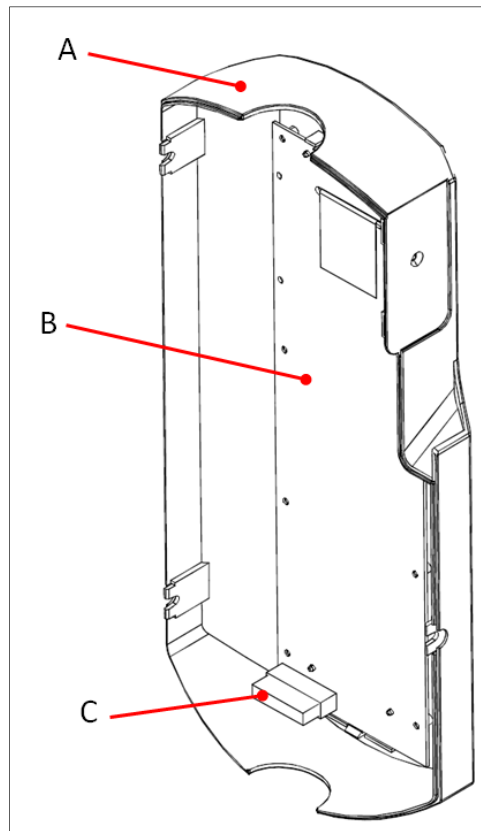

Fig.5.41

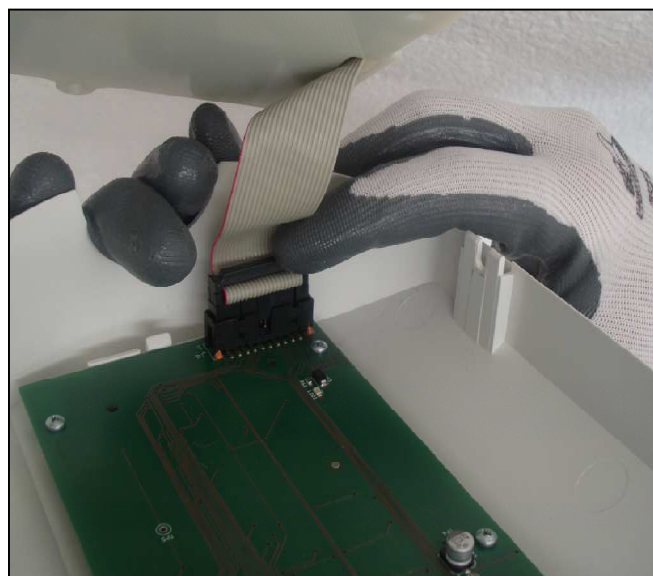

Fig. 5.42

A	FRONT PANEL
B	CONTROL DISPLAY BOARD installed in the FRONT PANEL
C	Connect flat cable connector between CONTROL POWER BOARD and CONTROL DISPLAY BOARD

5.5.9. STEP 8 - ASSEMBLING THE TIMER:

After arranged all the connections make sure you have assembled and installed all the 4 fixing screws of the timer referring to the pictures below.

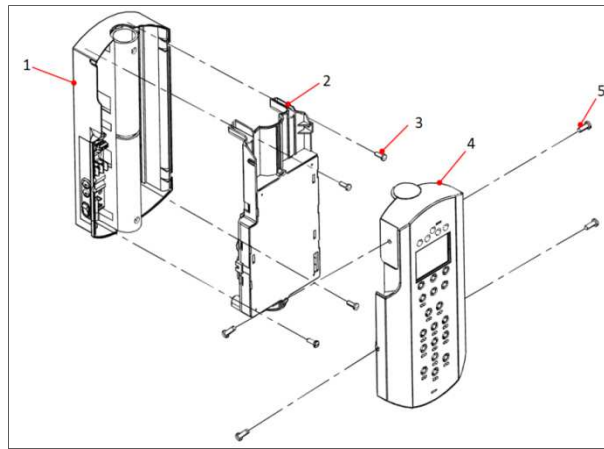

Fig.5.43

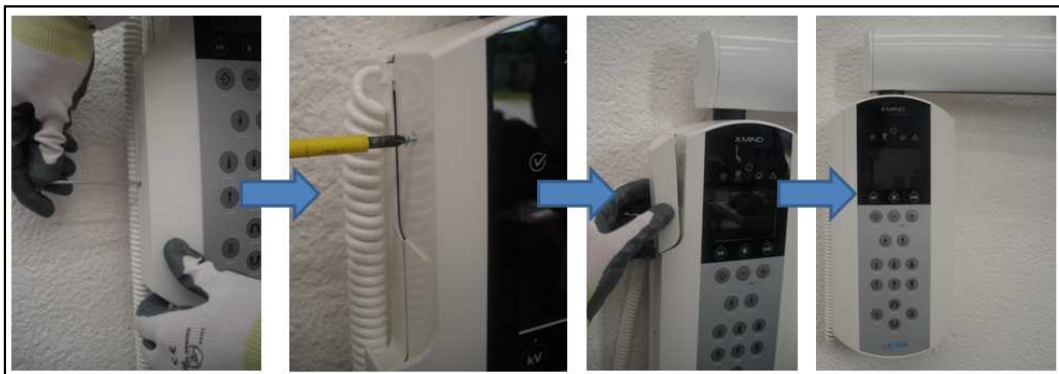

Fig. 5.44



PLEASE NOTE

Before closing the front panel of the control unit, please remind to insert the tube cap (A) on the opposite side where the bracket is installed.

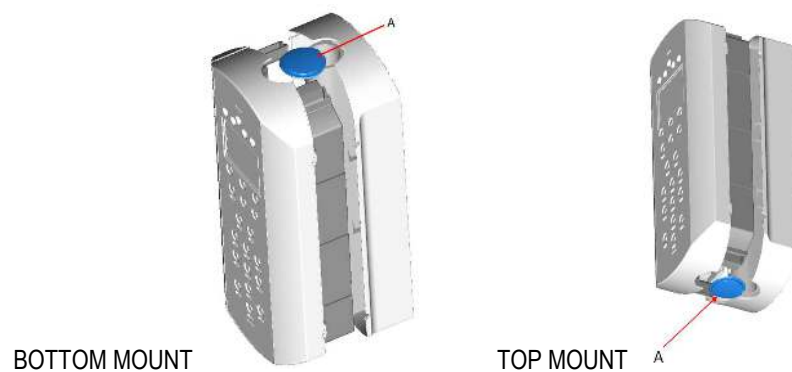

Fig. 5.45

6. INSTALL AND CONNECT X-MIND unity LIGHT (OPTIONAL)

RXINT Board



Fig. 5.46

Necessary cables and wires for the connection should be arranged before the installation of the X-MIND unity light.

This light needs an independent mains line (L + N) for the power supply and control cables (2 wires) coming directly from the control unit.



CAUTION

It is absolutely forbidden to install an exposure light different from the original part provided by de Götzen S.r.l. – Acteon Group.

The control unit circuit is dedicated for the X-MIND unity light functioning, connecting a different light to this circuit can damage the unit and compromise the overall safety of the system.

To install and connect X-MIND unity light please refer to the following instructions:

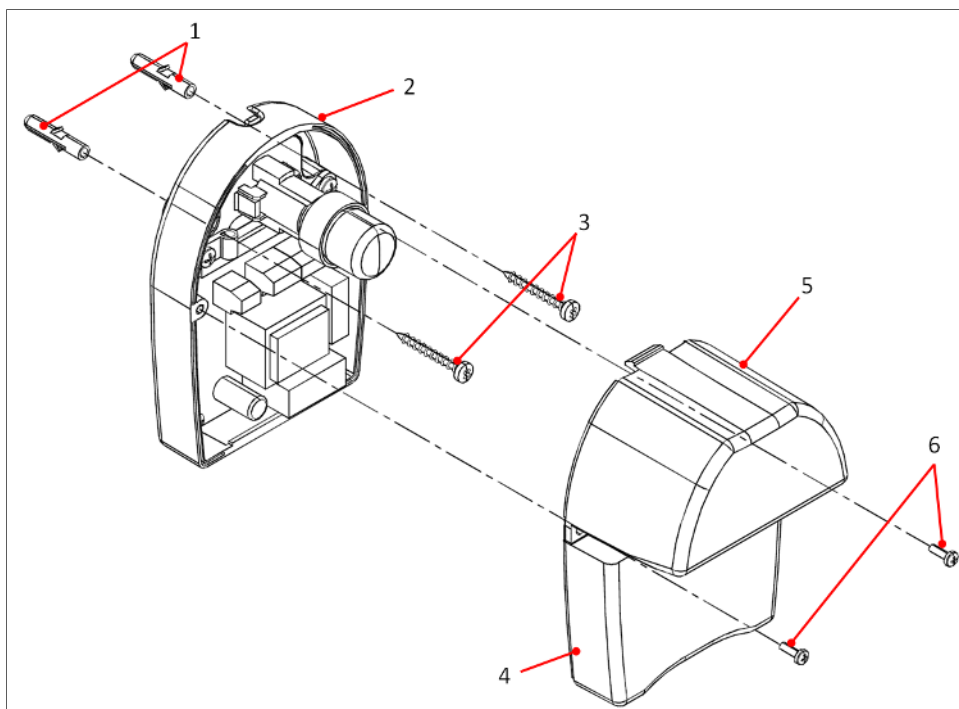

Fig. 5.47

1	Wall anchors
2	Back cover with PCB and terminals
3	Anchors screws
4	Front top cover
5	Front bottom cover
6	Fixing screws

 PLEASE NOTE

Maximum length of wires for the installation of the X-MIND unity light is 20 m (66 feet) and minimum section of the wires is 20 AWG (CSA/UL 300V/80°C)

1. Disassemble the X-MIND unity light case by unscrewing the 2 fixing screws (6).
2. Fix the back cover (2) to the wall by using the wall anchors (1) and anchors screws (3).
3. Connect the wires to the terminal as indicated in the figure below, it is important to respect polarity of L and N and S1 and S2. (For further details please refer to the wiring scheme in the chapter "ELECTRICAL SCHEME")

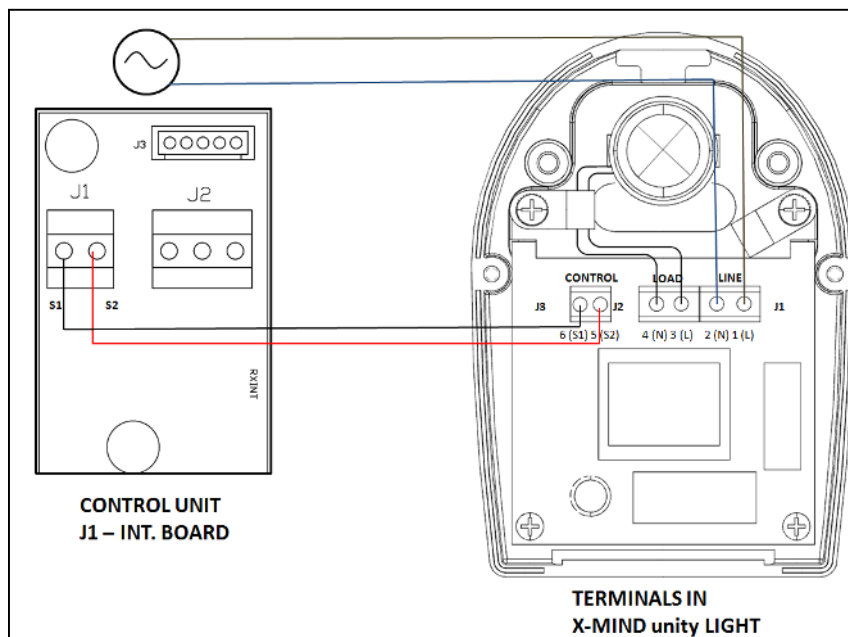

Fig. 5.48

4. Arrange connections in the X-MIND unity light as shown below, use the cable ties provided to fix the cable and always respect polarity.

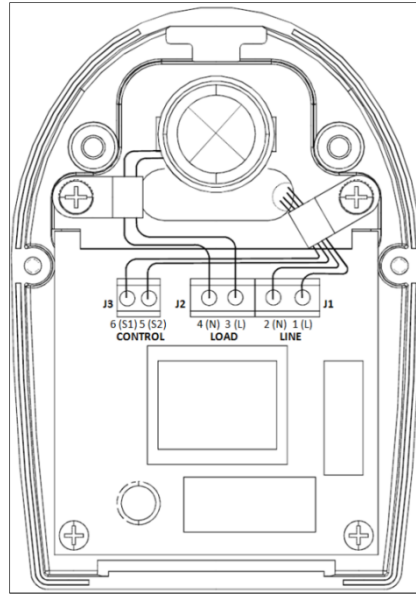

Fig. 5.49

5. Close the front covers (4) and (5) then screw in the fixing screws (6)



PLEASE NOTE

By default setting, the X-MIND unity light (when installed) is ON (lit) when the X-MIND unity is in ARMED mode (✔)
When the X-MIND unity goes in stand-by or is switched off, the X-MIND unity light will switch off.

7. INSTALL AND CONNECT THE REMOTE EXPOSURE SWITCH (OPTIONAL)

RXINT Board



Necessary cables and wires for the connection should be arranged before the installation of the remote exposure switch.
This switch needs a control cables (2 wires) coming directly from the control unit.

CAUTION

It is absolutely forbidden to install a remote exposure switch different from the original part provided by de Götzen S.r.l. – Acteon Group.

The control unit circuit is dedicated for the X-MIND unity remote exposure switch, connecting a different switch to this circuit can damage the unit and compromise the overall safety of the system.

To install and connect X-MIND remote exposure switch please refer to the following instructions:

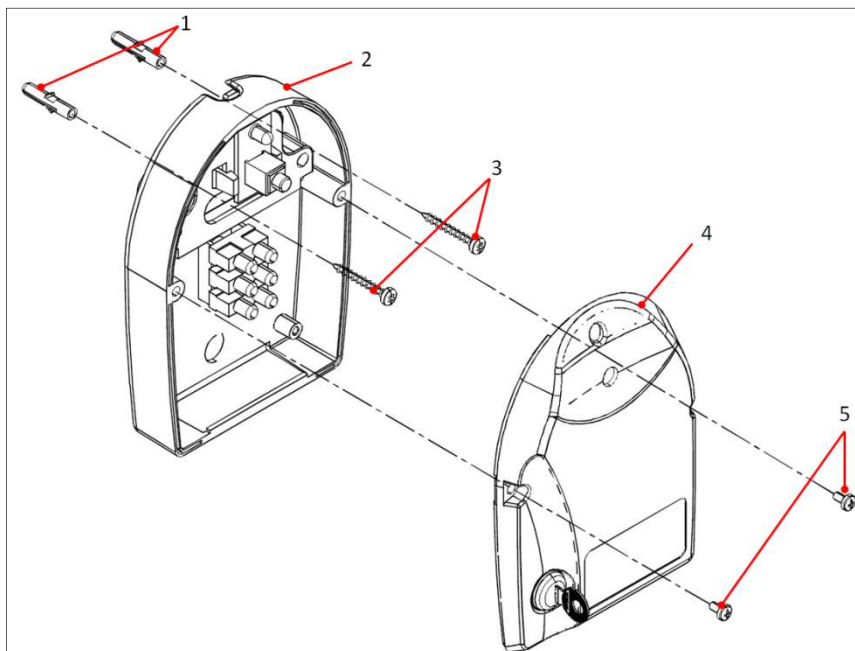

Fig. 5.50

1	Wall Anchors
2	Back cover with PCB and terminals
3	Anchors screws
4	Front cover
5	Fixing screws



PLEASE NOTE

Maximum length of wires for installation of the remote exposure switch is 20 m (66 feet) and minimum section of the wires is 24 AWG (CSA/UL 300V/80°C)

1. Disassemble the X-MIND unity remote exposure switch by unscrewing the 2 fixing screws (5).
2. Fix the back cover (2) to the wall by using the wall anchors (1) and Anchors screws (3).
3. Connect the wires to the terminal as indicated in the figure below, it is important to respect polarity. (For further details please refer to the wiring scheme in the chapter “ELECTRICAL SCHEME”)

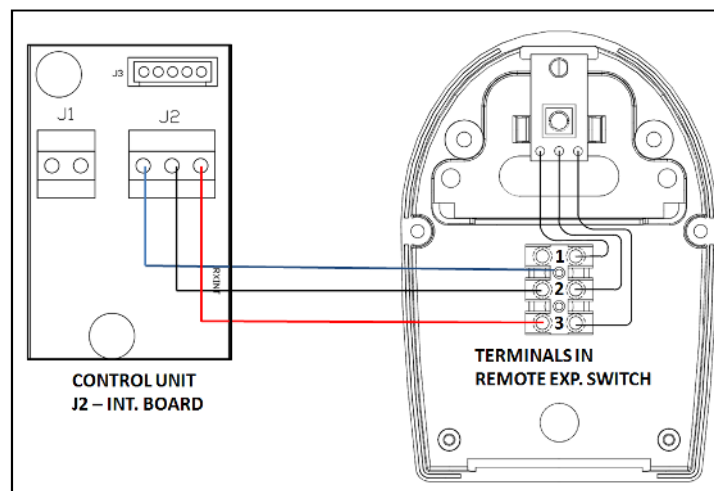

Fig. 5.51

4. Arrange connections in the remote exposure switch as shown below, use the cable ties provided to fix the cable and always respect polarity.

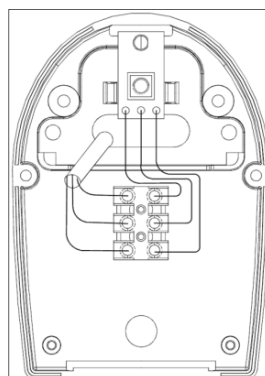

Fig. 5.52

5. Close the front cover (4) then screw in the fixing screws (5).

6. START UP

CAUTION

When all the connections are completed, the installer must check the electrical safety and functions of the system.

WARNING

Before switching on the system, verify that the mains value is within the range reported on the label of the device.

INSTRUCTIONS

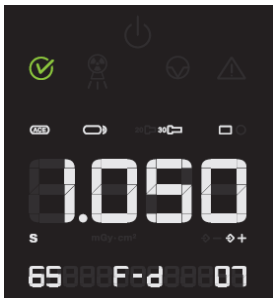
 <p>Fig. 6.1</p>	<ul style="list-style-type: none">▶ Toggle the main switch (1) located on the left part of the timer to the “I” position (ON)▶ The display will light up
 <p>Fig. 6.2</p>	<ul style="list-style-type: none">▶ The “ready” green light turns on indicating that the system is powered and ready for exposure according to the loading factors indicated in the control panel display-.▶ The leds of the set parameters automatically light up.▶ The exposure time is shown on the display.

 CAUTION

If an error is detected when the system is turned on, the anomaly is indicated as follows:

- Intermittent beeping sound*
- Intermittent flashing of the MALFUNCTION indicator *
- the error code (E) appears on the display (refer to “ERRORS” Chapter)*
- all the control panel functions and x-ray emission are inhibited*

In this case it is possible to reset the error pushing the “memo” key or turn off the timer and then turn it back on.

If the error happens again and it is not possible to restore it, call your local Acteon customer service.



PLEASE NOTE

The exposure time and parameters which appear on the display are the last that were set before the timer was turned off.



PLEASE NOTE

If the timer remains inactive for a few minutes, it switches to the stand-by mode.







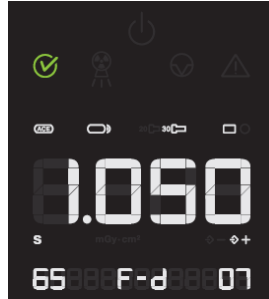

Press any key on the control panel to restore it to the operative armed mode.

7. CONFIGURATION

The “X-MIND unity“ x-ray system is factory configured in “*standard mode*”.

On the control panel, the led relevant to the following exposure parameters will light up:



	Ready for x-ray exposure (Armed mode)
	X-Ray Exposure Time selected
	Type of cone installed (rectangular or circular shaped x-ray beam output)
	SSD distance 20 [cm] (8") = SHORT CONE (circular or rectangular) 30 [cm] (12") = LONG CONE (circular or rectangular)
	X-ray tube voltage 60kV / 65kV / 70kV
	X-ray tube current 4mA-7mA
	Selection of the x-ray detector support type : F-d : FILM, D Speed F-e : FILM, E Speed F-f : FILM, F Speed Dig : Digital X-Ray Sensor PSP : Phosphor plates ACE : The “ACE” code inside the list of selected type of supported detector (F-d, F-e, F-g, F-f, DIG, PSP) is available only when a Sopix/Sopix ² Inside is installed and properly armed.
	When the integrated SOPIX/SOPIX ² Inside sensor is installed and properly armed you can run the X-MIND unity with the ACE system activated ² . This icon lights up after the exposure performed in ACE mode.

² Refer to the operator’s manual of the SOPIX/SOPIX² Inside x-ray sensor for more informations or contact the technical support of Sopro. : ZAC Athélia IV • Avenue des Genévriers • 13705 LA CIOTAT cedex • FRANCE • Tél +33 (0) 442 98 01 01 • Fax +33 (0) 442 71 76 90 • E-mail: info@sopro.acteongroup.com • www.sopro.acteongroup.com

The following exposure times [s] are available in the X-MIND unity:

0,020 – 0,025 – 0,032 – 0,040 – 0,050 – 0,063 – 0,080 – 0,100 – 0,125 – 0,160 – 0,200 – 0,250 – 0,320 – 0,400 – 0,500 – 0,630 – 0,800 – 1,00 – 1,250 – 1,600 – 2,000 s



PLEASE NOTE

These times are in compliance with IEC 60601-2-7 standard according to the 2nd and 3rd edition of the IEC 60601-1 and with the ISO 497 series R'10 recommendations.



PLEASE NOTE

These values of the programmed exposure times MAY NOT be modified.

Certain exposure values have been predefined which depend on the selection of the operating parameters:

- ▶ cone (8"/12")
- ▶ type of patient (ADULT/CHILD)
- ▶ x-ray technique
- ▶ intra-oral exam



PLEASE NOTE

If one so desires, it is possible to change these values by means of the dedicated key buttons previously indicated.

Possible modifications of the exposure values:

- ▶ x-ray anodic voltage (typical: 60kV/65kV/70kV)
- ▶ x-ray anodic current (typical: 4mA/6mA/7mA)
- ▶ type of patient (ADULT/CHILD)
- ▶ x-ray technique

→ refer to chapter 5

Possible modifications of the parameters:

- ▶ Number of exposure switches
- ▶ Cone size (20cm - 8" / 30cm - 12")
- ▶ Cone type (Square / Round)



7.1. ADVANCED SETTINGS MENU (SERVICE ONLY)

WARNING

This procedure can be used only by authorized and trained technician.

“de Götzen® S.r.l. - ACTEON Group” shall not be held liable for misuse of the information provided in this chapter.

It is available an advanced settings menu for SERVICE that allows only the authorized Installer to set and verify some parameters of the device.

1. Press and keep pressed keys  and  for 5 seconds till the message “SET” is shown on the display.
2. After a couple of seconds is shown the first parameter, in the bottom part of the display is shown the name of the parameter.

3. Use keys  to scroll parameters.

4. When it is shown the desired parameter press  key to enter the under menu.

5. Icons  start blinking.

6. Use keys  to scroll available settings.

7. Press  key to confirm and save the selection.

8. Press  key to exit from menu, or wait some seconds without pressing buttons to automatically exit..

SERVICE MENU - AVAILABLE SETTINGS

IDENTIFICATION	DESCRIPTION	RANGE	CUSTOMIZABLE
Time Restore	Restore factory time	- Yes / No	Yes
Errors Log	See errors list	- Scroll errors	Clear errors list
Cone Type	Cone type installed / selected	- Short cone - Long cone - Rectangular cone	Yes ³
Remote button	Wired remote switch enable	ON/OFF	Yes
E.Count / -G	Number of exposure (tens)	- 0....9999 (Read only)	No
On count /-G	Number of power-up (tens)	- 0....9999 (Read only)	No
Lamp Mode	Define Exp. Light functioning	- rdy (ON when in armed mode) - EMIS (ON during exp.)	Yes
Leds Test	Verify functioning of leds	- Start test only	Start test only
Display Test	Verify functioning of display	- Start test only	Start test only
Keys Test	Verify functioning of keys	- Start test only	Start test only
Version	Control unit firmware version	- Read only	No
generator ver	X-Ray Source assembly firmware version	- Read only	No

³ Only authorized installers and technicians are authorized to modify the cone configuration

8. CHECKING THE INSTALLATION

CAUTION

Checking the installation and the relevant system functions after the installation or after service of the X-MIND unity is fundamental to warranty the safety of the people and proper functioning of the device.
In case advise promptly and clearly that the device must not be used.

WARNING

During these procedures X-rays will be emitted! Please take all precautions in order to avoid accidental exposure to ionising radiation!

8.1. CHECKING THE CONFIGURATION

Checking the control panel, make certain that all LED corresponding to the required configuration are lit; otherwise, modify parameters in order to have the right configuration.

8.2. CHECKING THE TIMER OPERATION

1. Check the correct operation of the control panel by selecting different exposure times
2. Check the time on the display

8.3. CHECKING THE EXPOSURE

1. Set an exposure time of 1s
2. Take and extend the exposure switch on the timer to a safety distance of at least 2 meters (6 ft) from the tube head
3. Press the  x-ray button on the x-ray exposure switch and keep it pressed until the acoustic signal (beep) stops and

the yellow led  turns off

PLEASE NOTE

If the "X-RAY" key is released early, the exposure is immediately interrupted and the E109 error message appears on the display.

At the end of the exposure the green PAUSE led flashes until the tube heads cooling cycle completes  PAUSE

4. The display indicates the actual exposure time
5. All the timer functions are inhibited

8.4. CHECKING THE OPERATION OF THE TUBEHEAD

take several exposures and check that:

- ▶ there are no errors
- ▶ the led of the selected tube head is lit
- ▶ the exposure button switch led is lit over the whole duration of the acoustic signal (beep)

8.5. CHECKING THE ABSORBED POWER

To check the power absorbed by the radiographic system an AC ammeter must be used

1. Connect the instrument to the power supply line
2. Set the x-ray to 65kV - 7mA - 2 s on the control panel
3. Carry out an exposure and read the current value on the instrument



PLEASE NOTE

***The radiographic system X-MIND unity complies with the requirements when:
The absorbed current is $\leq 8,5A$ with 100 - 240 VAC nominal value
Otherwise, check the electrical system or call the Acteon Customer Service number listed on page 3 of this manual***

8.6. CHECKING THE ELECTRIC SYSTEM

To check the electrical system an AC voltmeter must be used:

1. Measure the voltage from mains terminals
2. Measure and record the line voltage
3. Set an exposure of 65kV - 7mA - 2 s on the control panel
4. Proceed to the exposure and measured the line voltage during exposure



PLEASE NOTE

***The electric system complies with the requirements when:
 $(V_0 - V_1) / V_{0est} \leq 0,03$
Otherwise, check the electrical system or call the Acteon Customer Service number listed on page 3 of this manual***

9. BASICAL CHECKING OVERALL SYSTEM FUNCTIONS



PLEASE NOTE

Please refer to the Maintenance instruction Manual for the full list of checks.

PARTS	CHECK DESCRIPTION	X
WALL MOUNTING	Ensure that the wall support is adequate, the system is properly installed to the wall and fixing anchors are properly tighten.	
LABELS CHECKING	Ensure that all the labels on the system are available and properly attached. Furthermore check that they are readable and correct with the SN reported on the documents.	
SYSTEM ROTATING PARTS	Ensure that all rotating parts have a functioning mechanical stop to avoid cables twisting.	
SYSTEM STABILITY	Check that all the movements are smooth and no forcing. Check that the system maintains the position without further movements after releasing it.	
COVERS INSTALLATION	Ensure that all the enclosures and covers are properly installed (including all the screw caps) and not damaged. Make sure the bottom slide cover of the bracket is properly installed.	
POWER SWITCH FUNCTIONING	Verify that the power switch is properly functioning and that the power indicator is lit on the control panel.	
CONTROL PANEL FUNCTIONING	When the system is ON, verify that all the buttons and settings are functioning and available.	
LOCAL AND *REMOTE EXPOSURE BUTTON * if installed	Verify that the exposure buttons are functioning properly, check also exposure LED located on the switches.	
EXPOSURE INDICATORS	Make several exposures and verify that the exposures indicators are functioning.(icon on the control panel, led on exposure button and audible signal from control unit)	
EXPOSURE INTERRUPTION	Select longest exposure time available and using "+" button. Start an exposure but release switch before the end of the exposure. Verify that the display shows an error and malfunction indicator is ON. Pressing "Clear" button the system back to normal operation.	
OPERATOR INFORMATION	Ensure that the Operator has received the whole documentation provided with the system and the necessary information in order to operate the system according to safety measures.	

10. CHECKING THE EXPOSURE FACTORS

! WARNING

During these procedures X-rays will be emitted! Please take all precautions in order to avoid accidental exposure to ionising radiation!

10.1. CHECKING THE X-RAY TUBE VOLTAGE (kV)

The radiographic voltage is measured using a calibrated “non-invasive” instrument.

Please refer to your local regulatory body for dedicated test specifications.



Please check "TECHNICAL DATA" chapter for reference values.

10.2. CHECKING THE X-RAY TUBE CURRENT (mA)

The radiographic current is measured by connecting a multimeter to the 2 test points available in the fork.

Following the instructions below to perform this measure.

INSTRUCTIONS

 <p>Fig.10.1</p>	<ol style="list-style-type: none"> 1. Remove fixing screw located at bottom side of the fork.
 <p>Fig.10.2</p>	<ol style="list-style-type: none"> 2. After removed the screw, move back and slide down the bottom cover of the fork.

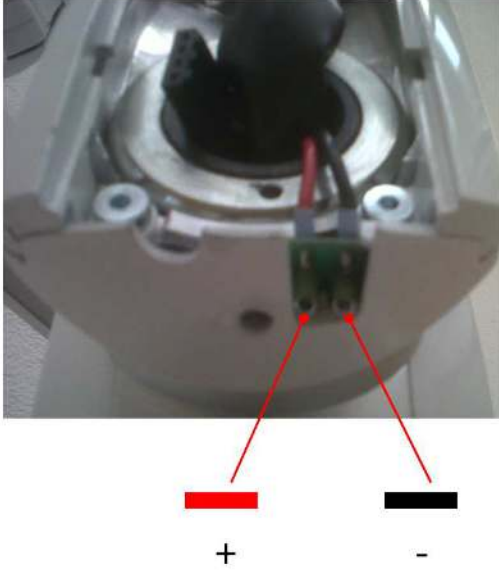
 <p>Fig.10.3</p>	<p>3. If Sopix/Sopix² Inside sensor is installed, disconnect the USB cable and ACE cable. Otherwise proceed to next step directly.</p>
 <p>Fig.10.4</p>	<p>4. Connect the multimeter on the 2 test points and set the instrument on VDC mode. Take an exposure long at least 1 sec. and read the value displayed.</p> <p>5. To know the mA value apply this conversion to the value read on the multimeter: 1 VDC = 1 mA</p>

 PLEASE NOTE

The type and location of test point could be different basing on production necessity.

Please check with your local regulatory body for specific test specifications.

 WARNING

Re-installing Sopix/Sopix² Inside, follow carefully installation and connection instructions as reported in its dedicated installation manual.

! WARNING - **!** CAUTION

Remove the fork cover **ONLY** to check the X-ray tube current.

In normal condition of use, **NEVER** operate the device or leave the device without the presence of the lateral enclosure of the fork (example shown in the picture below) or without the proper fixing of the enclosure on the fork.

In case the Sopix/Sopix² Inside is installed, also the x-ray sensor support must be present and properly fixed on the cover.

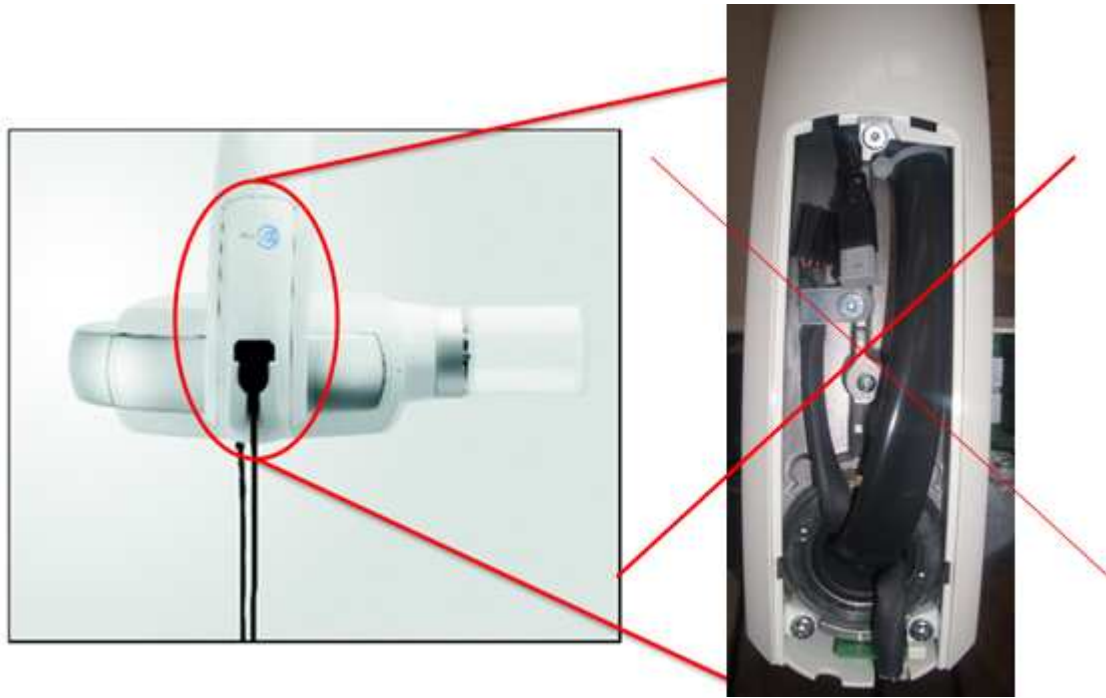

Fig. 10.5

11. DIAGNOSTIC

11.1. X-RAY CALIBRATION PROCEDURE



CAUTION

Perform this operation only if necessary or suggested by the Technical Support Service

During this operation x-rays will be emitted!

It is mandatory to adopt all the safety measures relevant to radioprotection.

Here below these instructions will explain how to perform X-ray tube calibration procedure.

1. Press and keep pressed key mA  for 5 seconds until message "TUBE CALIBRATION" appears on the display
2. Take a safety position far from the x-ray beam, press and keep pressed the exposure key . On the display will appear "CAL. IN PROGRESS" message, Exp. Led  is lit and an intermittent acoustic sound is emitted.
3. At the end of the procedure, acoustic sound stops and on the display appears "CAL. SUCCESS" message.
4. After waiting the pause time (it will be longer than the normal rest time), the timer back to standard functioning and it is ready for a new exam.

PLEASE NOTE

The calibration procedure takes about 50s

After this procedure, PAUSE led  is blinking and all the functions are inhibited. Please wait until it completes the cooling time due to the tube calibration before perform any further operation.

12. ERROR MESSAGES

In case of malfunctioning or error events, the display will show an error code together with acoustic signals (5 beeps). Furthermore an error symbol code is shown on the display, warning the operator about the error status.

All functions are inhibited until the error status is fixed or restored.

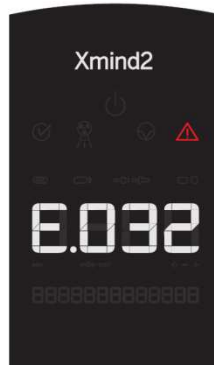



Fig. 12.1



Some errors can be cleared by pressing the reset button  on the keypad.

The following chart gives a list of error messages that may appear while the **X-MIND unity** radiographic system is working.

Error codes are made by letter “E” followed by a number that identifies unit in fault (timer or tubehead) and other 2 numbers that identify the error.

Unit number:

“1”: Fault it is located in the timer (control unit)

“2”: Fault it is located in the tubehead

This chart also includes the causes of the error messages and what to do to solve them:

Code	Message	Description	Resettable
E101	memory fail	EEPROM fault	NO
E102	memory fail	I ² C bus EEPROM fault	NO
E103	memory fail	EEPROM DMA readings fault	NO
E104	memory fail	EEPROM DMA writings fault	NO
E105	no response from generator	Lost communication between inverter and generator	NO
E106	wrong response from generator	NAK response from inverter	YES
E107	emission start fail		YES
E108	emission too long		YES
E109	button released beforehand		YES
E110	wrong use of button	pressione pulsante di esposizione in situazione di "pronto" disattivo	YES
E111	keyboard pressed at boot	Keyboard pressed during boot time	NO
E112	button pushed at boot	Exposure button pressed beforehand	NO
E113	wrong use of keyboard	Keys pressed during an exposure	YES
E114	button release timeout	Exposure button released beforehand after an exposure	YES
E115	wrong parameters in generator	Exposure parameters (kV, mA, exposure time, mode) does not match with the ones set in the control box	YES
E116	generator reset during emission	inverter has been resetted during an exposure	YES
E117	calibration start fail	Calibration	YES
E118	calibration too long	Calibration tme too long	YES
E119	button pushed during cooling	Exposure button pressed beforehand pushed during a functionality exposure	YES
E120	cooling time disabled	Functionality pause disabled	YES
E121	button pushed during stand-by	Exposure button pressed beforehand during stand-by	YES
E122	memory fail	Parameters out of range	NO
E123	power relay fail	power relay failure (relay OFF)	NO
E124	power relay fail	power relay failure (relay ON)	NO
E125	power board fail	power board failure	NO
E126	power board fail	power board failure	NO
E127	power board fail	power board failure	NO
E128	power board fail	power board failure	NO
E201	generator memory	Inverter EEPROM error	NO
E202	generator memory	Inverter I ² C EEPROM error	NO
E203	generator memory	Inverter EEPROM DMA readings fault	NO
E204	generator memory	Inverter EEPROM DMA writings fault	NO

Code	Message	Description	Resettable
E205	generator not calibrated	Calibration not yet done	YES
E206	tube voltage too low	Anodic voltage too low	YES
E207	tube voltage too high	Anodic voltage too high	YES
E208	electrical discharge on hv		YES
E209	tube current too low	Anodic current too low	YES
E210	tube current too high	Anodic current too high	YES
E211	filament voltage too low	Filament voltage too low	YES
E212	filament voltage too high	Filament voltage too high	YES
E213	tube unit not connected	High voltage unit not connected	NO
E214	button released beforehand	Enable signal released beforehand during an exposure	YES
E215	generator internal power supply	12V internal voltage too low	NO
E216	generator internal power supply	12V internal voltage too high	NO
E217	generator mode	Wrong exposure enabling signal activation	YES
E218	safe circuit fail	Security interlock fault	NO
E219	tube current too low	Mean anodic current too low	YES
E220	tube current too high	Mean anodic current too high	YES
E221	no tube voltage feedback	Missing HV feedback	NO
E222	ACE acquisition fail	X-rays not detected by Sopix	YES
For the errors that can't be cleared by the reset button on the keypad, please contact your installer or your local Acteon customer service			

13. SUGGESTED MAINTENANCE AND REPAIR

In order to guarantee safety of the radiographic system, it is necessary to set up a maintenance schedule. Additional information relevant to the mandatory maintenance can be found in the Maintenance Instructions of the X-MIND unity.

The RESPONSIBLE ORGANIZATION is responsible for organising and observing a maintenance schedule which must be executed by qualified technicians who must be able to certify their work with a "Declaration of Conformity".

CAUTION

Please contact your local state regulatory body for information regarding inspection schedules for this x-ray.

CAUTION

- To ensure patient's and operator's safety and high image quality, the device must be well maintained as described in the accompanying documents every time it is needed. For other maintenance operations, refer to the installation and maintenance manual and to the maintenance guide supplied.
- The RESPONSIBLE ORGANIZATION of the device is responsible for scheduling and having preventive maintenance carried out at least every 12 (twelve) months, which consists in maintenance carried out by qualified, authorised professional technicians. It is the RESPONSIBLE ORGANIZATION's responsibility to arrange for this service and to assure that the personnel performing this are fully qualified to service X-MIND unity x-ray equipment.
- The RESPONSIBLE ORGANIZATION must carry out routine controls on a daily basis to ensure optimal device performance. These checks must be performed also to complete the installation of the X-MIND unity X-Ray System and as part of the recommended maintenance as indicated in the accompanying documents. Failure to perform these checks may result in an installation that does not comply with U.S. Radiation Performance Standards 21 CFR Subchapter J.
- The manufacturer shall not be held liable for damage or injuries caused by failure to carry out inspections or acceptance tests or by incomplete maintenance.
- Repairs and replacements of any component must be carried out solely by authorised and highly qualified personnel and only using genuine spare parts supplied by de Götzen® S.r.l. - ACTEON Group.
- Do not operate the unit if there is the threat of an earthquake. Following an earthquake, ensure that the unit is operating properly and it's mandatory to check it before completely under any aspect before using it again. Failure to observe this precaution may expose patients an environment to hazards.

CAUTION

For Italy: Medical electrical equipment malfunctions resulting from incomplete or inadequate maintenance can cause serious adverse events⁴.

For Italy refer to Presidential Decree 14/01/1997, Legislative Decree No. 81/2008 (as subsequently amended and modified).

⁴ Recommendation No.9, April 2009 - Recommendation for the prevention of adverse events resulting from medical electrical equipment malfunctions - Italian Ministry of Labour, Health and Welfare

13.1. CLEANING THE OUTER SURFACE

Clean the external surface using a damp cloth and non-corrosive and non oil-based detergent and disinfect it using a non-aggressive medical detergent. Do not spray detergent or disinfectant directly on the device. The spacer cone may be cleaned with cotton wool soaked with surgical alcohol.

CAUTION

- Turn off and disconnect the device from the supply mains before carrying out cleaning operations.
- Do not spray products directly on the device. Apply the product on a clean cloth.
- Always use disposable protective covers for the applied parts.
- Do not use UV systems to disinfect the equipment, as exposed parts of the device can turn yellow or discolour.
- To avoid any potential hazard or danger to operators and patients, contact your authorized Acteon Technical Representative immediately if you experience any unusual operation, mechanical issues, or equipment malfunction

13.2. DISPOSAL



The WEEE symbol  indicates that, at the end of its lifespan, the product must be disposed of separately from other waste, in compliance with Directive 2002/96/EC.

Refer to the implementation standards in your country. EU Council Directive 2002/49/EC (WEEE) defines a common approach intended to avoid, prevent or reduce harmful effects due to the exposure to environmental noise and to the disposal of electric and electronic equipment. This product is marked with the symbol shown above. This product must not be disposed of together with domestic waste. It must be taken to a special waste collection centre to be recovered and recycled. The crossed-out wheeled bin identifies a product placed on the market after the 13th of August 2005 (see IEC EN 50419:2005). This product is subjected to Council Directive 2002/96/EC (WEEE) and national implementation standards. Refer to your supplier for the disposal of this product.

Proper disposal of this product will help protect the environment.

For further details on the disposal of this product, please contact local authorities, the provider of the domestic waste disposal service or the outlet where you have purchased it.

13.3. MAINTENANCE INSTRUCTIONS

1. Turn the main power switch to 'OFF'
2. Release the spring of the arm B of the SCISSOR arm using the enclosed scissor arm key
3. Remove the tube head
4. Remove the wall plate guard
5. Remove the terminal board cover and disconnect the SCISSOR arm cable
6. Remove the bracket plug and the guard slab
7. Remove the SCISSOR arm and its cable from the bracket
8. Remove the bracket from the wall plate
9. Check the vertical alignment of the wall plate: adjust if required
10. Check the six fixing screws of the wall plate: tighten if required
11. Clean the old lubricating grease from the bracket shaft: should the bracket shaft be damaged, install a new bracket
12. Clean the old lubricating grease of the bracket bushing: should the bracket bushing be damaged, install a new bracket
13. Grease the bracket shaft (use only the type specified by the de Götzen S.r.l.!!)
14. Lubricate the bracket bushing with lubrication grease (use only the type specified by the de Götzen S.r.l.!!)
15. Install the bracket in the wall plate
16. Check the SCISSOR arm cable: should it be damaged, send the SCISSOR arm to Acteon for repairs
17. Check the SCISSOR arm guards
18. Replace the damaged guards
19. Clean the old grease from the shaft: should the shaft be damaged, send the SCISSOR arm to Acteon for repairs (see page 3 for contact info)
20. Lubricate the SCISSOR arm shaft with lubricating grease (use Molikote D grease ONLY as specified by the manufacturer) and reposition it in the bracket
21. Reinstall the SCISSOR arm cable in the bracket and the wall plate, connect it to the terminal board and reinstall the terminal board cover
22. Position the guard slab in the bracket
23. Position the bracket plug
24. Position the plate guard
25. Check the electric contact of the tube head: if damaged, send the tube head to Acteon for repairs (see page 2 for contact info)
26. Clean the old grease from the tube head assembly shaft
27. Grease the assembly shaft of the tube head with a thin layer of lubricating grease (use Molikote D grease type ONLY)
28. Position the tube head again
29. Re-tension the spring of the SCISSOR arm B using the scissor arm key provided
30. Turn unit on and check the correct operation of the radiographic system



PLEASE NOTE

Please refer to Maintenance Instructions document of the X-MIND unity for more details.

13.4. REPLACEMENT OF FUSES

CAUTION

Potentially lethal shock hazard!
Make sure the mains is disconnected before proceed with the following operations.

Depending by the installation type, the x-ray control unit of the X-MIND unity is equipped by 1 or 2 fuses located on the electronic board reachable from the outside by means of a flat screwdriver.

1. Single Fuse (Live): wall mounting version-permanently installed
2. Double Fuse (Live and Neutral): mobile version of the X-MIND unity.

CAUTION

respect exactly the ratings and the characteristics of the fuses as stated in the labels and accompanying documents.

To replace them proceed as follows:

1. Locate the fuses and main switch at left-bottom side of the timer.

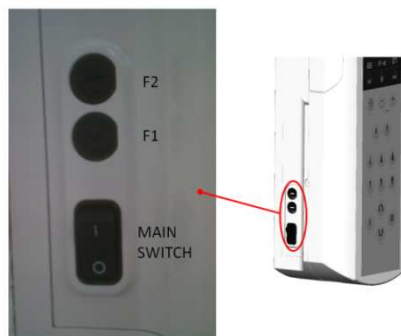

Fig. 13.1

F1= Live Fuse

F2= Neutral (installed only on X-MIND unity mobile unit versions)

2. Turn the power off putting the mains switch on "0"
3. Using a flat screwdriver unscrew (anticlockwise) the fuse holder and replace the fuse.



Fig. 13.2

5. Remove the fuse



Fig. 13.3

6. Replace the fuse with same rated fuse type:



Fig. 13.4

MANUFACTURERS RATING PLATE	100 - 240 VAC
FUSES F1 type - 5x20	T10A H 250V
FUSES F2 type - 5x20	T10A H 250V

4. After replacement, screw in the fuse holder to close it.



Fig. 13.5

9. Turn the power back on

13.5. CHANGING THE BEAM LIMITING DEVICE (Collimator Cone)

13.5.1. ROUND CONE (SHORT AND LONG)

To disassemble the round cone (both short and long) it is necessary unscrew the 3 screws located at the base of it.

For long cone it is necessary the long Allen key provided with the system.

To fix the cone it is enough screw in the 3 screws.

Always pay attention to the orientation of the cone, there are two sites (2) in order to center the cone on the screws (1).

Here below an image shows location of the screws.

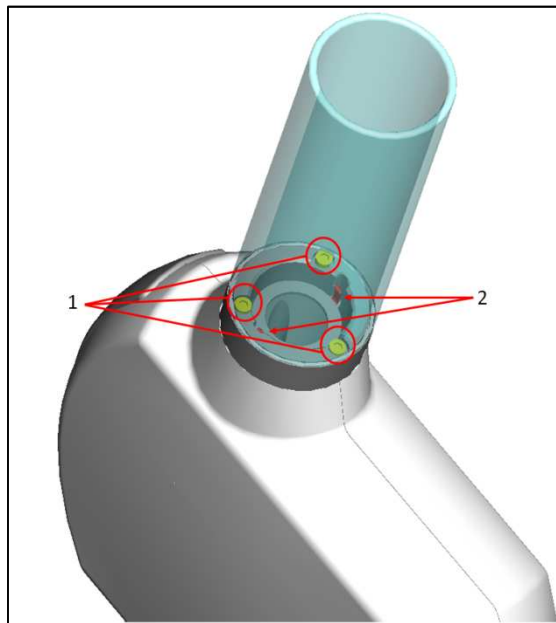

Fig.13.6

Cone disassembled

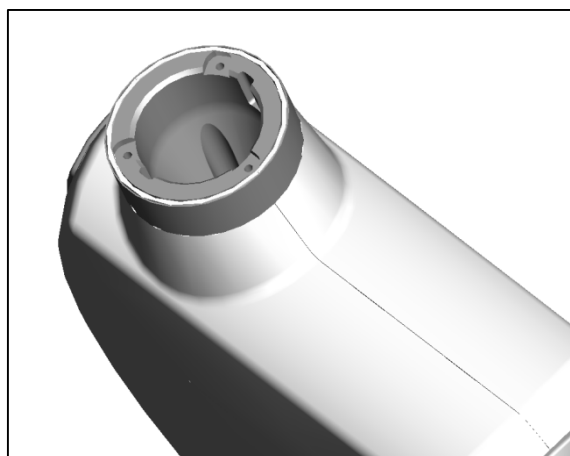

Fig.13.7

13.5.2. RECTANGULAR CONE

Rectangular cone parts:

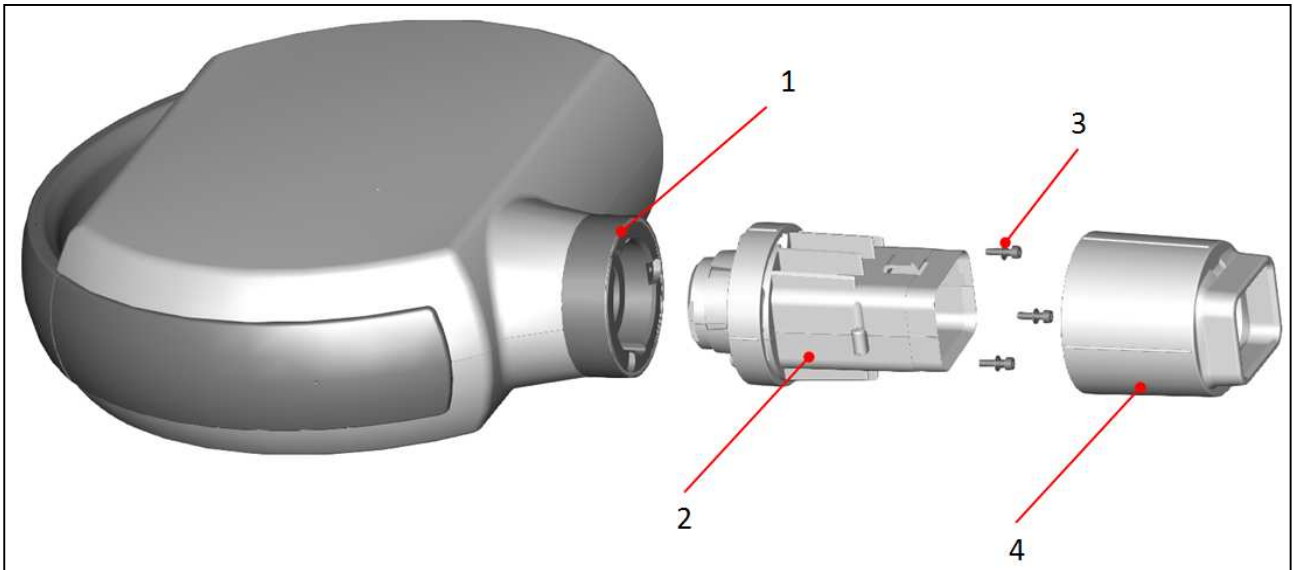

Fig.13.8

1	Tubehead cone support
2	Internal part (beam limiter)
3	Fixing screws (x3)
4	Beam Limiting Device cover

INSTRUCTIONS TO ASSEMBLE RECTANGULAR CONE:

	<p>Disassemble the existing cone. Take out the rectangular cone and disassemble the cone cover from beam limiter unit in order have access to fixing screws.</p>
	<p>Fix the beam limiter unit to cone support by means of the 3 screws provided.</p>
	<p>Install the cone cover on the beam limiter by pushing it on the 2 flaps until hear the click of right assembling. Lightly try to pull out the limiter assembly in order to check stability.</p>
	<p>The square cone properly installed should be able to rotate and not easily coming out.</p>

Fig.13.9

INSTRUCTIONS TO DISASSEMBLE RECTANGULAR CONE:

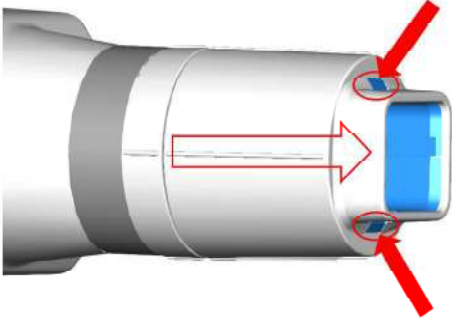
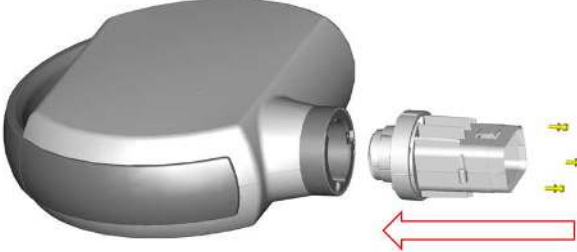
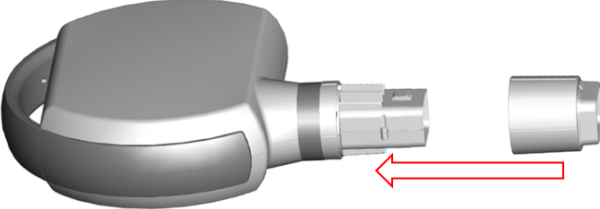
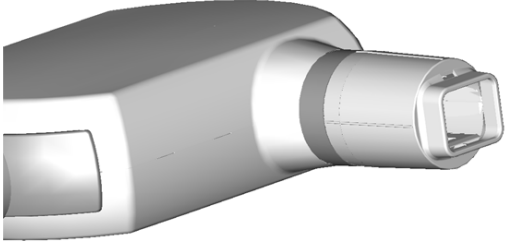

	<p>Disassemble the cone cover by pressing on the 2 blocks. After unlocked it, pull out the cone cover.</p>
	<p>Rotate the internal part of the cone in order to reach the fixing screws.</p>
	<p>Once unscrewed the 3 fixing screws remove the internal part of the cone.</p>

Fig.13.10

13.5.3. MODIFY INSTALLED BEAM LIMITING DEVICE IN X-MIND unity CONTROL UNIT

After completed mechanical operations of replacement of the cone, follow the instructions below to modify CONTROL UNIT configuration and select the cone installed.

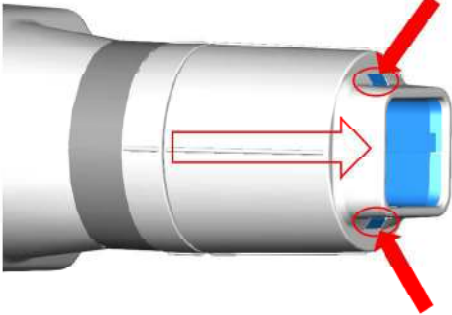
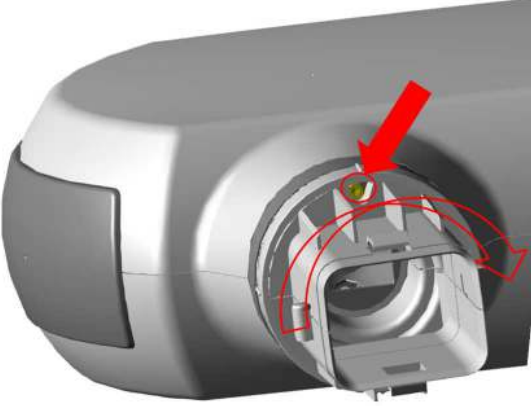
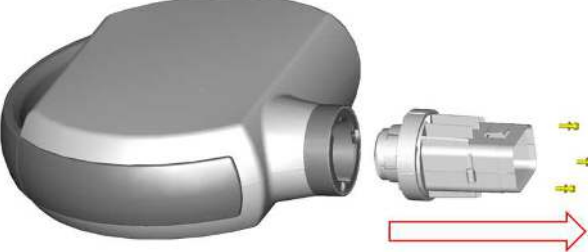

To modify cone selection it is necessary enter in the dedicated "SERVICE" menu.

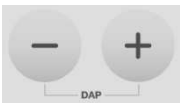
9. Press and keep pressed keys  and  for 5 seconds till the message "SET" is shown on the display.
10. After a couple of seconds is shown the first parameter, in the bottom part of the display is shown the name of the parameter.

11. Use keys  to scroll parameters.

12. When it is shown the parameter "CONE TYPE" press  key to enable modification.

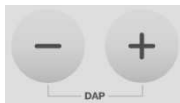
13. Icons  start blinking.

14. Use keys  to scroll available settings,  rectangular or round,  short or long (only for round type).

15. Press  key to confirm and save the selection.

16. Press  key to exit from menu.

CAUTION

The pre-programmed exposure values and the relevant dosimetric values, including the Dose Area Product, are dependent by the type and dimension of the beam limiting device installed.

Once the cone has been changed it is mandatory to update the internal settings of the x-ray control unit according to the instructions supplied in order to be sure that you're effectively using the same cone type and size indicated on the display of the control unit, otherwise all the pre-programmed exposure settings and relevant dose related information will be completely incorrect!

According to the paragraph 203.8.5.4 of the IEC 60601-2-65, in case you're using the X-MIND unity device together with the integrated SOPIX/SOPIX² Inside sensor, it is mandatory to install and use the original rectangular beam limiting device provided by the manufacturer of the X-MIND unity

13.6. HOW TO DISASSEMBLE THE TUBE HEAD

The tubehead can be disassembled only if it is strictly necessary for maintenance or service operations.

! WARNING **!** CAUTION

*The scissor arm has not been designed for use without tubehead.
This operation can cause serious injuries to the operator and damages to the device.
It is **ABSOLUTELY** mandatory to discharge the spring of the arm as described in the chapter "Balancing the scissor arm" on tubehead side or **SAFELY** block the arms together (as shown below) in order to avoid that the arm suddenly swings up when tubehead is removed.*

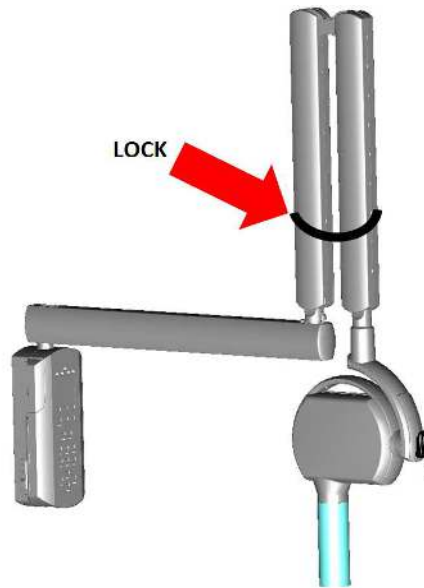





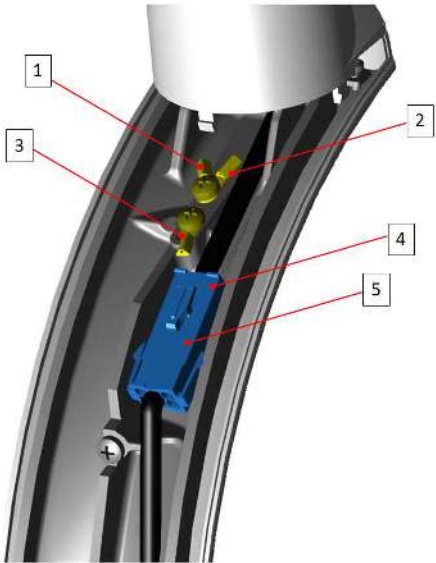
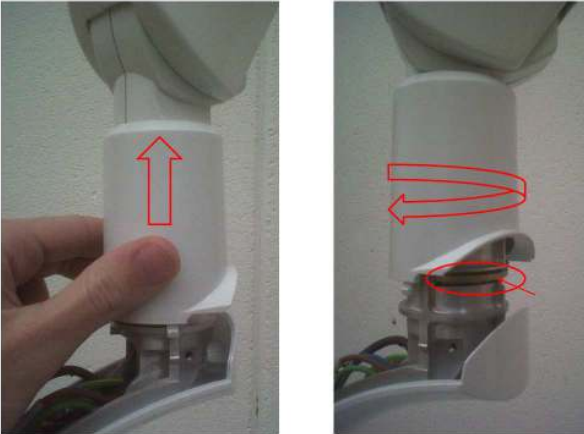

Fig.13.11

ASSEMBLY INSTRUCTIONS

	<p>6. Remove fixing screw located at bottom side of the fork.</p>
	<p>7. After removed the screw, move back and slide down the bottom cover of the fork.</p>
	<p>8. If the SOPIX/SOPIX2² Inside sensor is installed, disconnect USB cable connection (right picture) and ACE cable connection (left picture). Otherwise proceed to next step directly.</p>
	<p>9. Remove 3 fixing screws of the fork enclosure.</p>

	<p>10. Remove the fork enclosure.</p> <p>! WARNING - ! CAUTION</p> <p>Remember to assemble again the cover of the fork enclosure when re-connecting the tubehead!</p> 
	<p>11. Disconnect the ground ring (1) and ground ring (2) coming from the scissor arm by unscrewing the fixing screw. Disconnect the ground wire (3) coming from tubehead (3). Disconnect 6 poles connector male (4) and female (5). Make sure that all the cables are free before disassembling the tubehead.</p> <p>! WARNING - ! CAUTION</p> <p>Respect the proper assembly sequence of tooth lock washers between each ground protection ring.</p>
	<p>12. Lift the fork top cover and if necessary rotate it till have access to the half-moon clip.</p>



	<p>13. Push up the tubehead from the fork and pull out the half-moon clip.</p> <p>! WARNING - ! CAUTION</p> <p>Always ascertain that the half-moon clip is properly installed in its site when re-assembling the tubehead!</p>
	<p>14. After removing the half-moon clip, pull down the tubehead to disassemble it.</p> <p>Pay attention that cables are free and not blocked in order to avoid damage them.</p>

Fig.13.12

13.7. HOW TO re-ASSEMBLE THE TUBE HEAD

For re-assembling the tubehead, PLEASE FOLLOW INSTRUCTIONS ABOVE IN THE REVERSE WAY AND REMEMBER TO CONNECT AGAIN PROPERLY ALL THE CONNECTIONS.

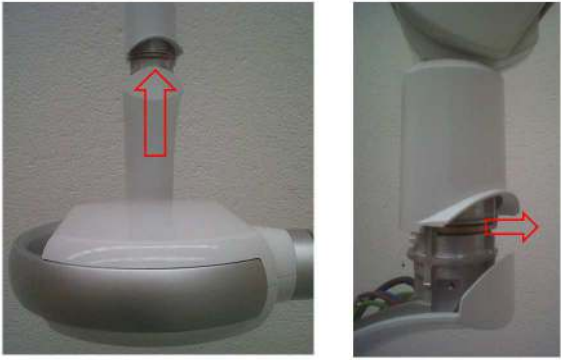
! WARNING

Re-installing Sopix/Sopix² Inside, follow carefully installation and connection instructions as reported in its dedicated installation manual.

14. TECHNICAL SPECIFICATIONS



PLEASE NOTE

Refer to Annex A of the Operator's Manual of the X-MIND unity

15. ELECTRICAL SCHEMES

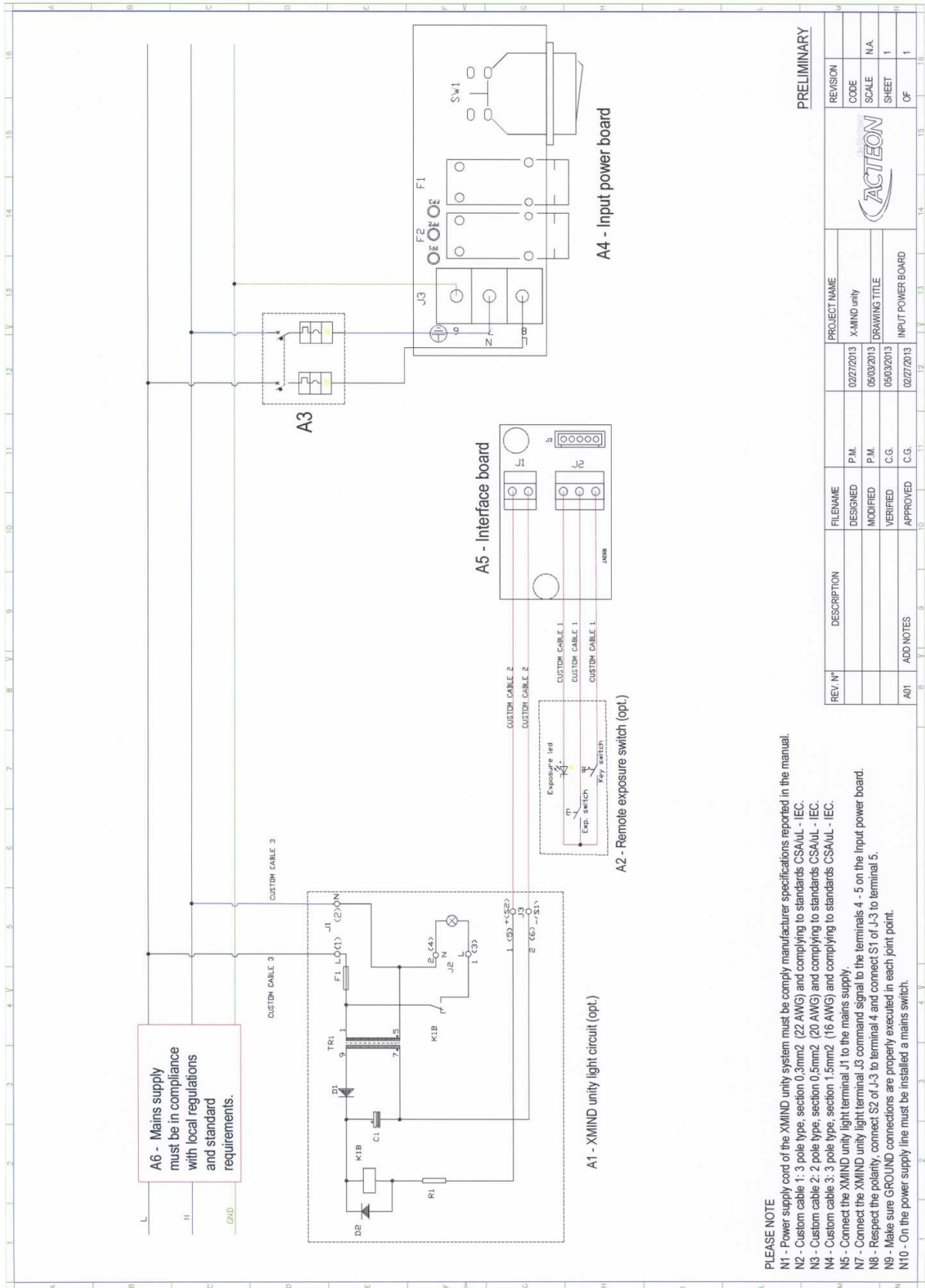

PRELIMINARY

REV. N°	DESCRIPTION	FILENAME	PROJECT NAME	REVISION
		DESIGNED	X-MIND unity	CODE
		MODIFIED		SCALE
		VERIFIED		SHEET
A01	ADD NOTES	APPROVED	02/27/2013	OF

REV. N°	DESCRIPTION	FILENAME	PROJECT NAME	REVISION
		DESIGNED	X-MIND unity	CODE
		MODIFIED		SCALE
		VERIFIED		SHEET
A01	ADD NOTES	APPROVED	02/27/2013	OF

- PLEASE NOTE**
- N1 - Power supply cord of the X-MIND unity system must be comply manufacturer specifications reported in the manual.
 - N2 - Custom cable 1: 3 pole type, section 0.3mm2 (22 AWG) and complying to standards CSA/UL - IEC.
 - N3 - Custom cable 2: 2 pole type, section 0.5mm2 (20 AWG) and complying to standards CSA/UL - IEC.
 - N4 - Custom cable 3: 3 pole type, section 1.5mm2 (16 AWG) and complying to standards CSA/UL - IEC.
 - N5 - Connect the X-MIND unity light terminal J1 to the mains supply.
 - N7 - Respect the polarity, connect S2 of J-3 to terminal 4 and connect S1 of J-3 to terminal 5.
 - N8 - Connect the X-MIND unity light terminal J3 command signal to the terminals 4 - 5 on the input power board.
 - N9 - Make sure GROUND connections are properly executed in each joint point.
 - N10 - On the power supply line must be installed a mains switch.

ELECTRICAL SCHEME NOTES

A1	Internal scheme of X-MIND unity light and connections (optional, sold separately)
A2	Internal scheme of X-MIND unity remote exposure switch and connections (optional, sold separately)
A3	Position and connection of bipolar 16A – 250V breaker/differential (Id ≤ 0.03A) switch
A4	Input power board layout and connections
A5	Mains supply must be in compliance with local and standard requirements.

CABLES TYPE AND CONNECTIONS (Max. Length 20 m - 66 feet)

N1	Power supply cord of the X-MIND unity system must be in compliance with manufacturer specifications reported in the manual and with the local regulations of the country of installation.
N2	Custom cable 1: 3 pole type, section 0.3mm ² (24AWG) and compliance to standards CSA/UL - IEC.
N3	Custom cable 2: 2 pole type, section 0.5mm ² (20AWG) and compliance to standards CSA/UL - IEC.
N4	Custom cable 3: 3 pole type, section 1.5mm ² (16AWG) and compliance to standards CSA/UL - IEC.
N5	Connect X-MIND unity light terminal J1 to the mains supply.
N6	Connect X-MIND unity light terminal J3 command signal to the terminals 4 - 5 on the input power board.
N7	Respect polarity, connect S2 of J3 to terminal 4 and connect S1 of J3 to terminal 5.
N8	Always respect polarity of LINE and NEUTRAL.
N9	Make sure GROUND connections are properly executed in each joint point.
N10	On the power supply line must be installed a mains switch able to isolate the unit from the supply mains.

Follow carefully indications reported in the manual and in the scheme, in case of doubt please contact your reference service office.

Respect and verify GND routing path indicated below:

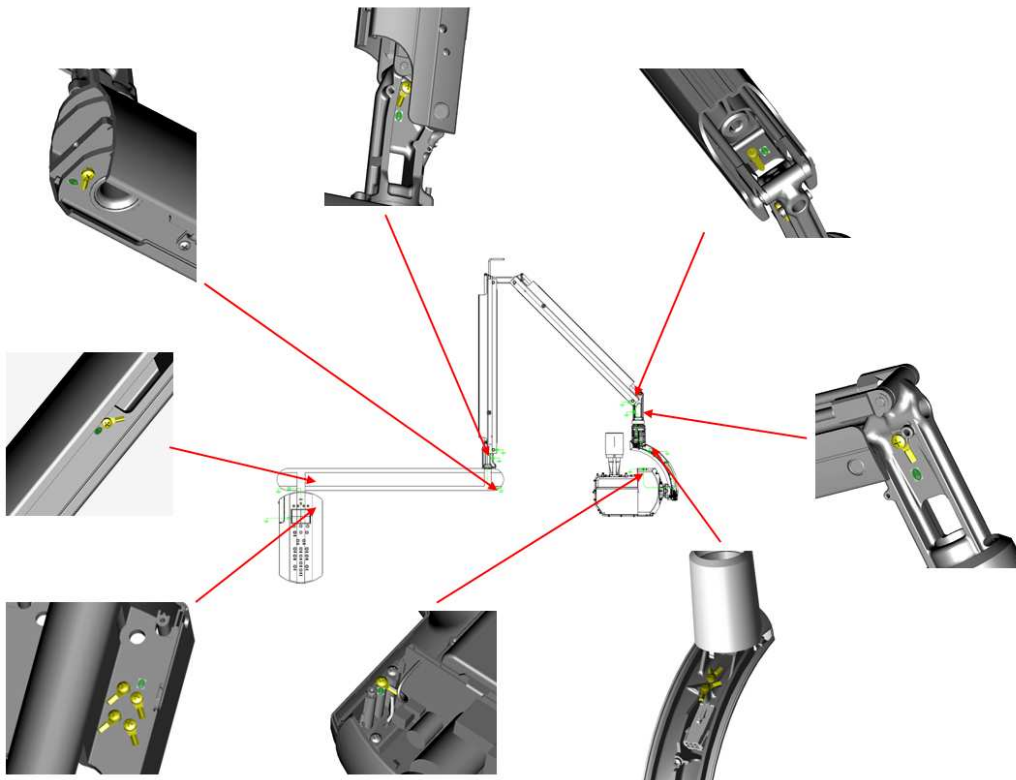

Always respect indications below to fix ground points:

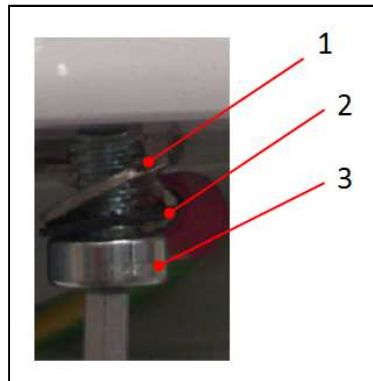

1	Ground ring
2	Tooth lock washer
3	Allen key screw

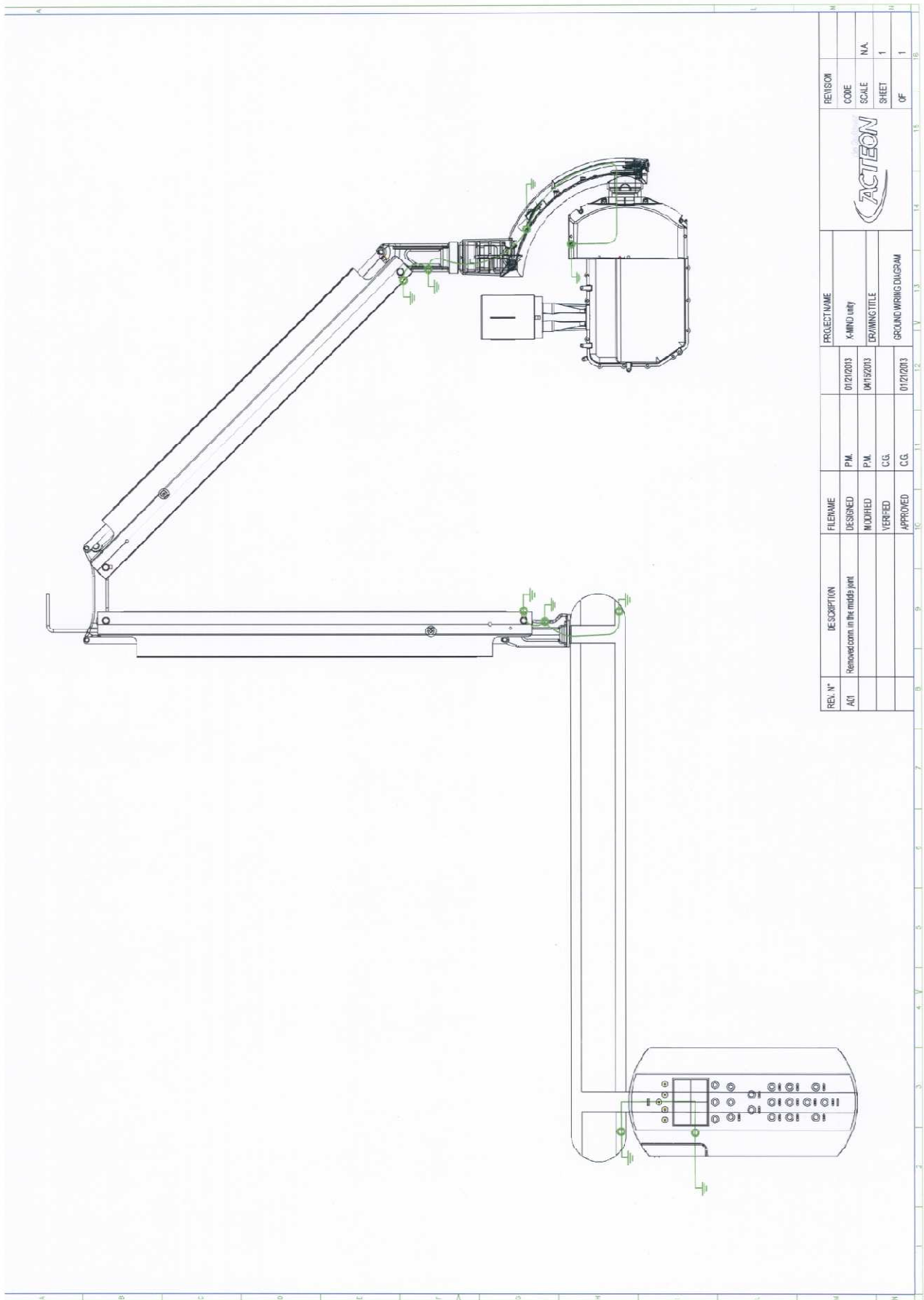

REV. N°	DESCRIPTION	FILENAME	DATE	PROJECT NAME	REVISION		
A01	Removed conn. in the middle part.	DESIGNED	01/21/2013	X-MIND unity	CODE	SCALE	N/A.
		MODIFIED	04/15/2013	DRAWING TITLE	SHEET	1	1
		VERIFIED	01/21/2013	GROUND WIRING DIAGRAM	OF	1	1
		APPROVED					



X-MIND unity Global Wiring Scheme

